

# 三菱 6X-145

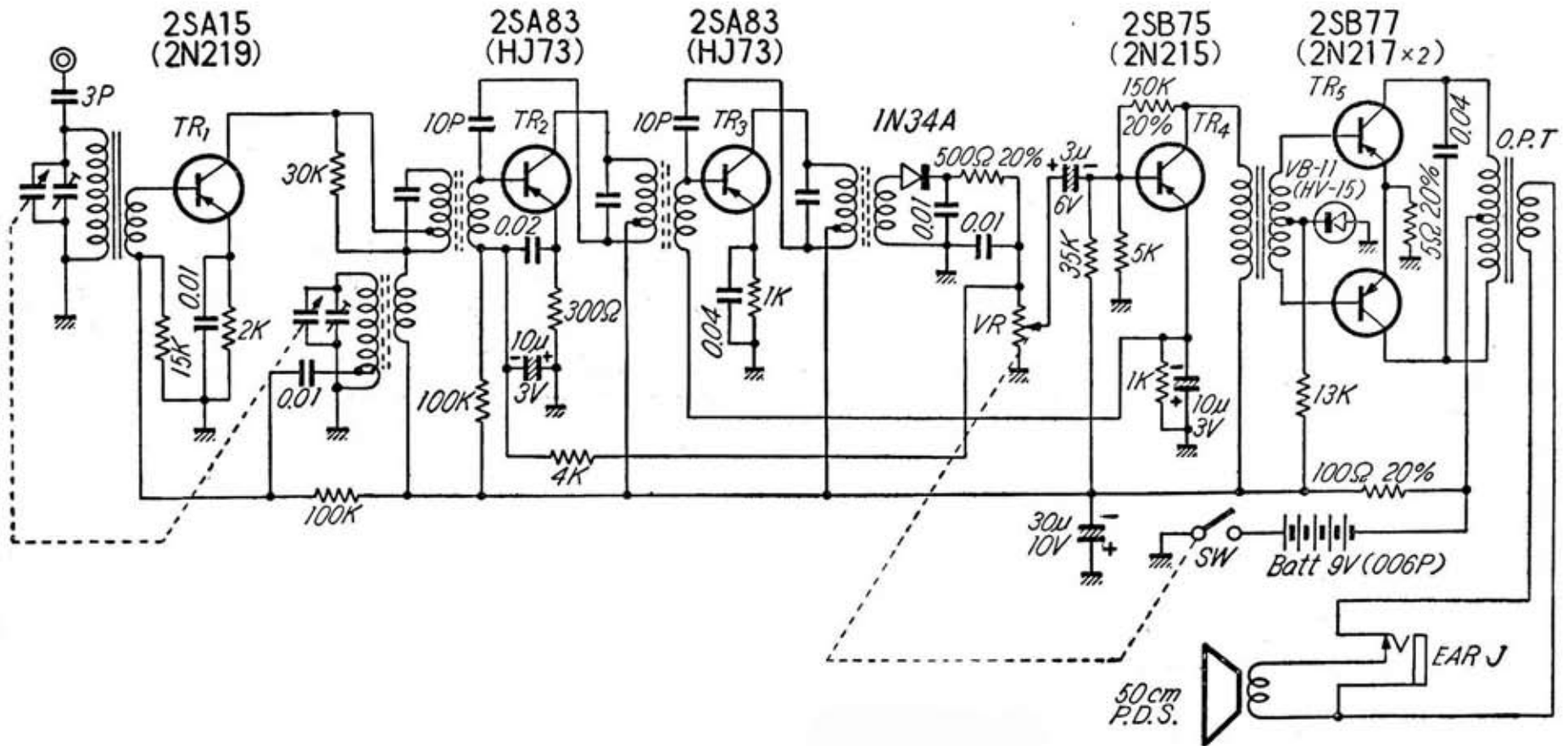

# MITSUBISHI 6X-145

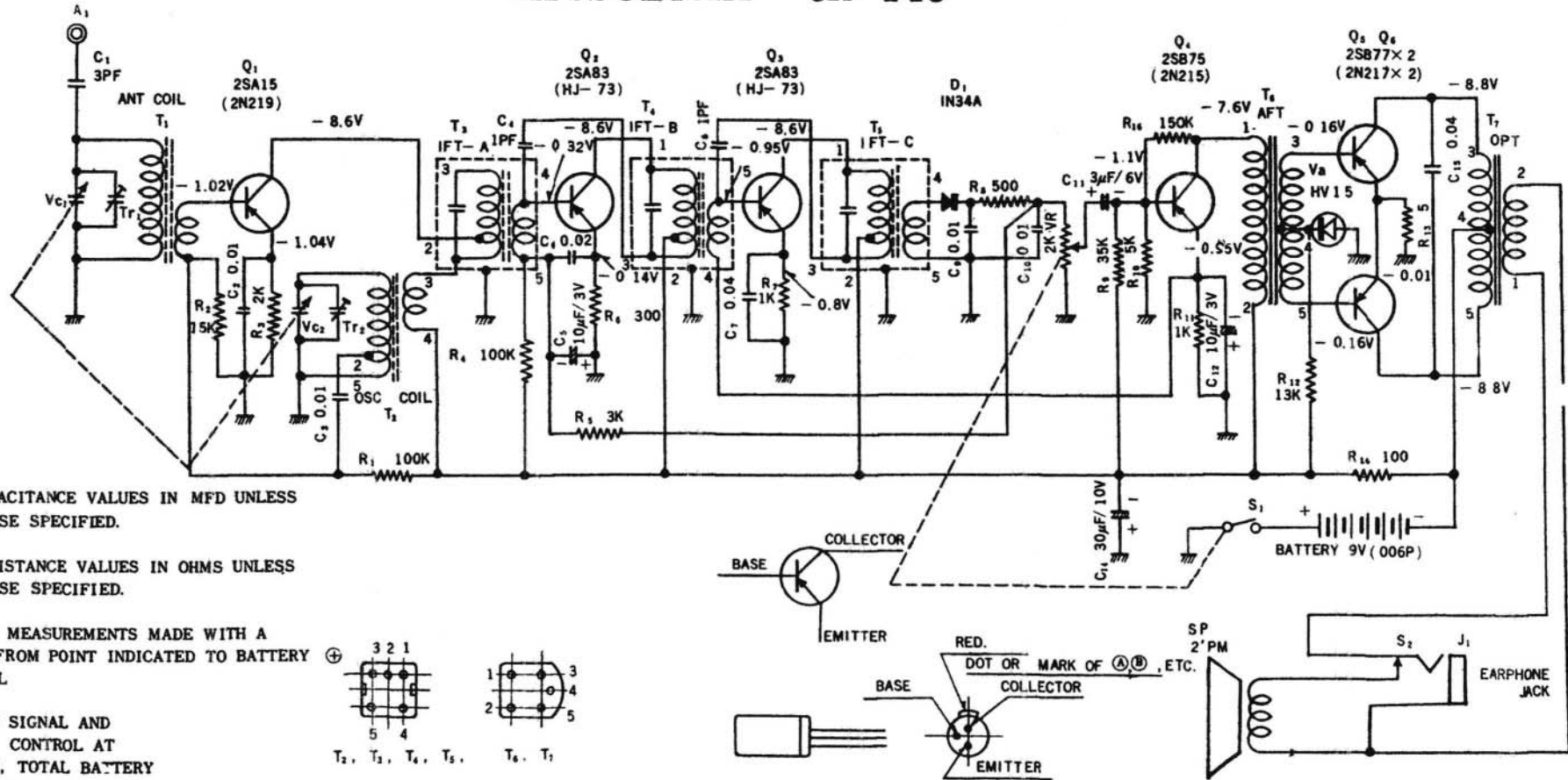

**NOTES :**

1. ALL CAPACITANCE VALUES IN MFD UNLESS OTHERWISE SPECIFIED.
2. ALL RESISTANCE VALUES IN OHMS UNLESS OTHERWISE SPECIFIED.
3. VOLTAGE MEASUREMENTS MADE WITH A V.T.V.M FROM POINT INDICATED TO BATTERY TERMINAL
4. WITH NO SIGNAL AND VOLUME CONTROL AT MINIMUM, TOTAL BATTERY DRAIN SHOULD BE APPROX. 6mA.

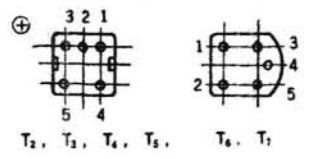

OSC COIL T<sub>2</sub>,  
IF TRANS. T<sub>3</sub>, T<sub>4</sub>, T<sub>5</sub>  
BOTTOM VIEW

A F TRANS T<sub>6</sub>  
OUTPUT TRANS T<sub>7</sub>  
BOTTOM VIEW

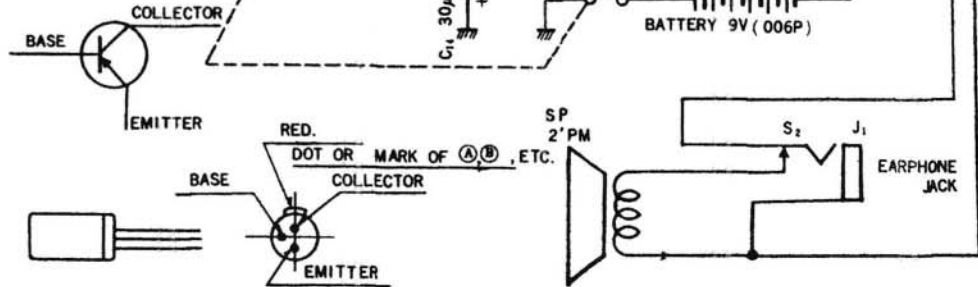

BOTTOM VIEW OF TRANSISTOR