

SM-18回路図

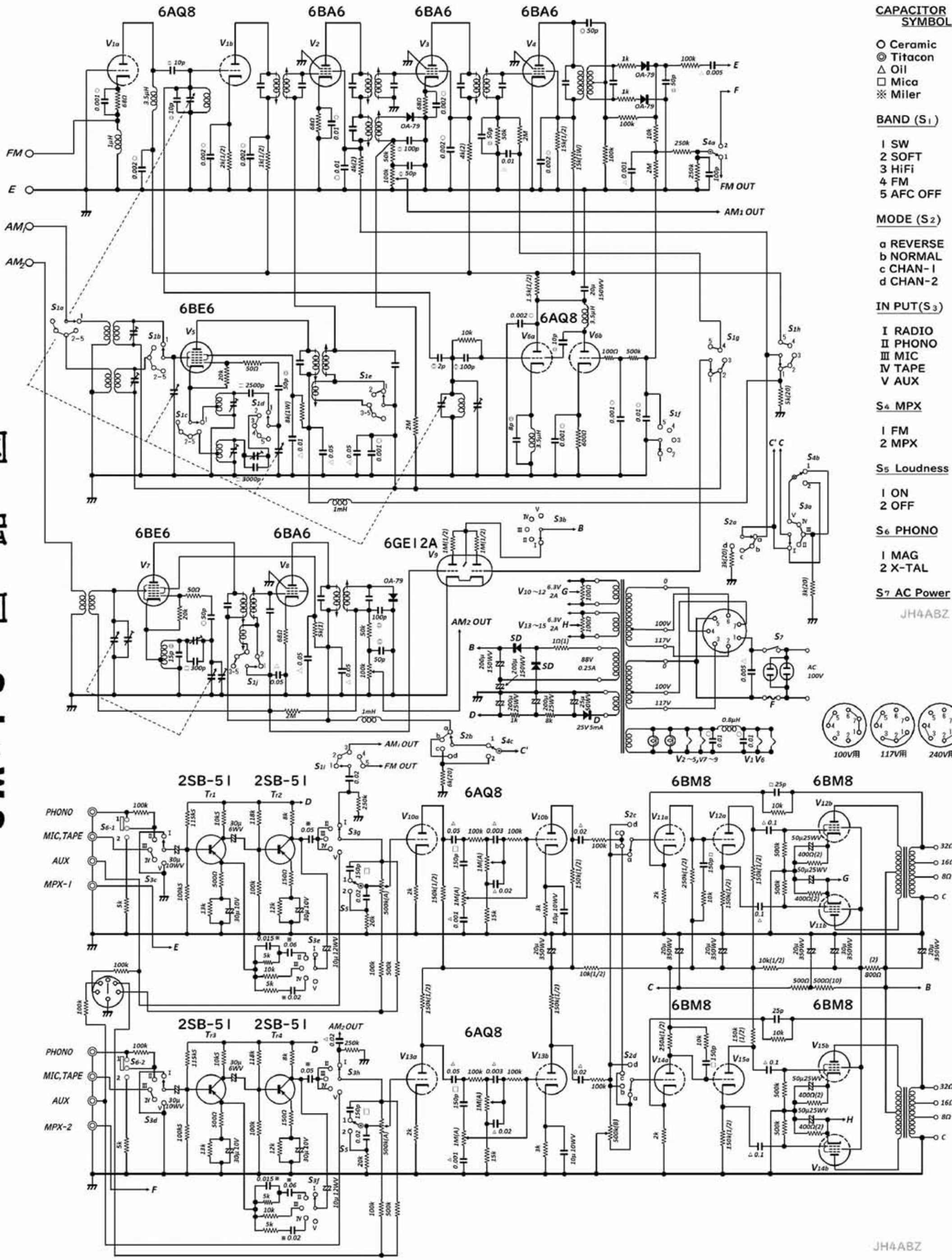

CAPACITOR SYMBOL

- Ceramic
- ◎ Titacon
- △ Oil
- Mica
- ※ Miller

BAND (S₁)

- 1 SW
- 2 SOFT
- 3 HiFi
- 4 FM
- 5 AFC OFF

MODE (S₂)

- a REVERSE
- b NORMAL
- c CHAN-1
- d CHAN-2

IN PUT(S₃)

- I RADIO
- II PHONO
- III MIC
- IV TAPE
- V AUX

S₄ MPX

- 1 FM
- 2 MPX

S₅ Loudness

- 1 ON
- 2 OFF

S₆ PHONO

- 1 MAG
- 2 X-TAL

S₇ AC Power

JH4ABZ

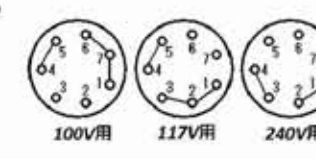

JH4ABZ