

Toshiba

15M-915

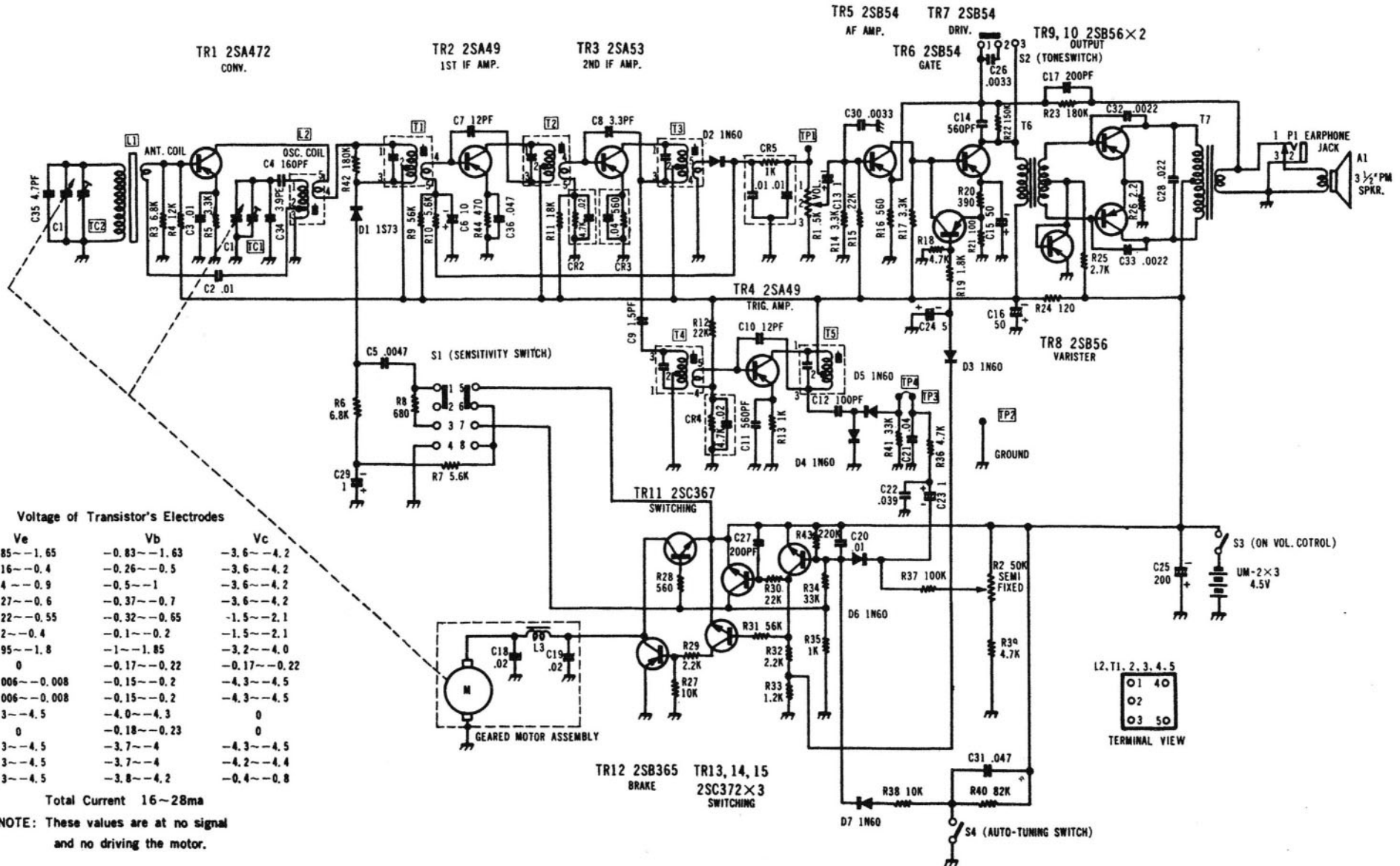

Voltage of Transistor's Electrodes

	Ve	Vb	Vc
TR1	-0.85~-1.65	-0.83~-1.63	-3.6~-4.2
TR2	-0.16~-0.4	-0.26~-0.5	-3.6~-4.2
TR3	-0.4~-0.9	-0.5~-1	-3.6~-4.2
TR4	-0.27~-0.6	-0.37~-0.7	-3.6~-4.2
TR5	-0.22~-0.55	-0.32~-0.65	-1.5~-2.1
TR6	-0.2~-0.4	-0.1~-0.2	-1.5~-2.1
TR7	-0.95~-1.8	-1~-1.85	-3.2~-4.0
TR8	0	-0.17~-0.22	-0.17~-0.22
TR9	-0.006~-0.008	-0.15~-0.2	-4.3~-4.5
TR10	-0.006~-0.008	-0.15~-0.2	-4.3~-4.5
TR11	-4.3~-4.5	-4.0~-4.3	0
TR12	0	-0.18~-0.23	0
TR13	-4.3~-4.5	-3.7~-4	-4.3~-4.5
TR14	-4.3~-4.5	-3.7~-4	-4.2~-4.4
TR15	-4.3~-4.5	-3.8~-4.2	-0.4~-0.8

Total Current 16~28ma

NOTE: These values are at no signal and no driving the motor.

