

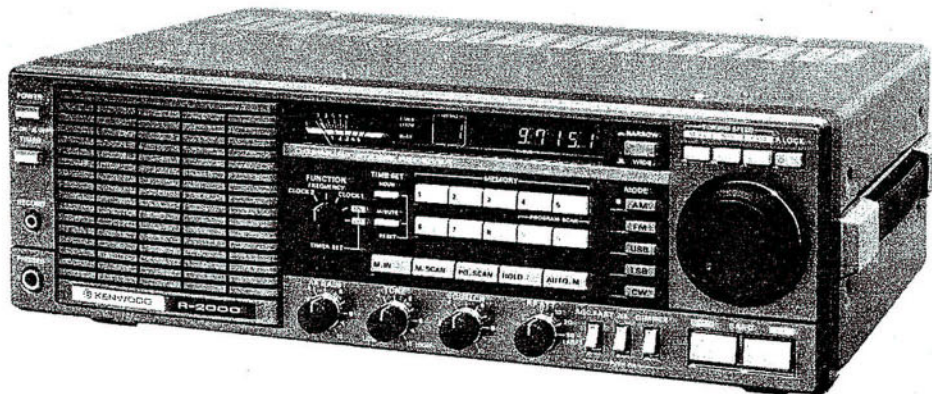

SERVICE MANUAL

R-2000 DCK-1

COMMUNICATIONS RECEIVER



CONTENTS

| | | | |
|-------------------------------------|----|------------------------|------------|
| SPECIFICATIONS..... | 2 | DISASSEMBLY..... | 22 |
| CIRCUIT DESCRIPTION..... | 3 | PACKING..... | 23 |
| PARTS LIST..... | 11 | ADJUSTMENT..... | 24 |
| PC BOARD VIEW AND SCHEMATIC DIAGRAM | | ADJUSTMENT POINT..... | 29 |
| RX UNIT (X55-1340-00)..... | 16 | TERMINAL FUNCTION..... | 30 |
| PLL UNIT (X50-1920-00)..... | 18 | BLOCK DIAGRAM..... | 31 |
| SWITCH UNIT (X41-1480-00)..... | 20 | DCK-1 (OPTION)..... | BACK COVER |
| SCHEMATIC DIAGRAM..... | 21 | | |

R-2000

SPECIFICATIONS

Frequency Range: 150 kHz ~ 30 MHz
 150 kHz ~ 26 MHz (W2 type)
 2 MHz ~ 30 MHz (X type)

Mode: AM, FM, SSB (USB/LSB), CW

Sensitivity: (0 dB μ = 1 μ V)

| Mode \ Frequency | 150 kHz ~ 2 MHz | 2 MHz ~ 30 MHz |
|----------------------|----------------------|-----------------------|
| SSB/CW (S+N/N 10 dB) | Less than 2 μ V | Less than 0.4 μ V |
| AM (S+N/N 10 dB) | Less than 20 μ V | Less than 4 μ V |
| FM (S+N/N 20 dB) | - | Less than 1 μ V |

Selectivity:

| Mode \ Selectivity | Selectivity | |
|--------------------|-----------------|------------------|
| AM-WIDE | 6 kHz (-6 dB) | 18 kHz (-50 dB) |
| AM-NARROW | 2.7 kHz (-6 dB) | 5 kHz (-50 dB) |
| SSB/CW | 2.7 kHz (-6 dB) | 5 kHz (-50 dB) |
| CW-NARROW | 500 Hz (-6 dB)* | 820 Hz (-60 dB)* |
| FM | 15 kHz (-6 dB) | 30 kHz (-50 dB) |

*: with YG-455C optional CW crystal filter

Image Ratio: Better than 70 dB

IF Rejection: Better than 70 dB

Frequency Stability: Within ± 300 Hz during the first hour after 1 minute of warm-up.

Within ± 50 Hz during any 30 minutes period thereafter.

Frequency Accuracy: $\pm 10 \times 10^{-6}$ or better (at normal temperatures)

Squelch Sensitivity: (threshold, 0 dB μ = 1 μ V)

AM/SSB/CW = Less than 3.12 μ V

FM = Less than 0.5 μ V

Audio Load Impedance: 4 Ω to 16 Ω

Audio Output Power: 1.5W (8 Ω load, 10% distortion)

Antenna Impedance: 50 Ω /500 Ω

Power Consumption: (at no signal) = 14W AC

13.8V DC, 0.6A (with optional DCK-1)

(at Memory Back-up) = 3W AC

13.8V DC, 0.1A (with optional DCK-1)

Power Requirements: 100/120/220/240V AC, 50/60 Hz

13.8V DC (with optional DCK-1)

Dimensions: 375 (14.8) W \times 115 (4.5) H \times 210 (8.3) D mm (inch)

Weight: 5.5 kg (12.1 lbs.) approx.

| Symbol | Destination |
|--------|-------------------------|
| K | U. S. A |
| M | General market |
| T | Britain |
| W | Europe |
| X | Australia & New Zealand |

CIRCUIT DESCRIPTION

RX unit X55-1340-00

R-2000 is a triple conversion general coverage receiver with a first IF of 45.85 ~ 45.90 MHz, 9.85 ~ 9.90 MHz second IF and a 455 kHz third IF.

Both low (50 Ω) or high (500 Ω) impedance antenna terminals are provided for all bands.

The signal supplied through the antenna terminal goes to the antenna fuse (100 mA) and three step RF attenuator (10, 20, and 30 dB). It next enters the BPF (Band Pass Filter), which divides the 0.15 ~ 30 MHz range into 6 bands; 0.15 MHz ~ 1 MHz, 1 MHz ~ 2 MHz, 2 MHz ~ 4 MHz, 4 MHz ~ 8 MHz, 8 MHz ~ 17 MHz and 17 MHz ~ 30 MHz. Q58: SN74LS145N converts the BCD band data signal from the PLL control circuit to select the appropriate BPF for the frequency selected.

Exiting the BPF, the signal, is fed to RF amp Q1: 3SK73(GR), first IF trap (operating at 40.875 MHz) and emitter follower Q2: 2SC1815 (Y).

The RF signal is mixed with the first local oscillator 45.9 ~ 75.85 MHz and converted to the 45.85 ~ 45.90 MHz first IF by balanced mixer Q3 and Q4: 3SK73(GR).

Q3 and Q4 drain voltage is supplied through a switching circuit consisting of Q5 and Q6 controlled by Q47 and Q48: 2SC1815 (Y) will turn off when the VHB signal is applied from the PLL control circuit in the (optional) VHF reception mode. At the same time, the first IF circuit input is switched to the converter by switching diodes D13 and D14: 1S2588.

After passing the first IF LC filter the signal is converted to the 9.85 ~ 9.90 MHz second IF by the second balanced mixer Q7 and Q8: 3SK74(L) using the 36 MHz second local oscillator injection signal.

The second IF signal passes through ceramic filter F1 (f_0 : 9.875 MHz) and is converted to the 455 KHz third IF by the third balanced mixer Q9 and Q10: 3SK73(GR) using the 9.445 ~ 9.395 MHz third local oscillator injection signal.

The signal is applied to the NB gate D15, 16. A part of the signal is also applied to the NB (Noise Blanker) amplifiers on the PLL unit via buffer Q11: 2SC1815(Y). The signal output from the NB gate is switched to the appropriate bandwidth third IF filter (F2 ~ F5 of 455 kHz), then fed to the third IF amplifiers.

The IF filter bandwidths are: F3; 2.7 kHz, F4; 6 kHz and F5; 15 kHz. Filter F3 is used in the AM narrow, SSB and CW wide modes, F4 in the AM wide mode and F5 in the FM mode. Filter position F2 is provided for the CW narrow mode and an optional YG-455C or YG-455CN filter can be used.

The third IF amplifiers are divided into two systems; one for the FM mode and one for all other modes.

In the FM mode, the signal passing through F5 is amplified by Q32: TA7060P, Q33: 2SC1675(L) and Q34: μ PC577H, then detected by ceramic discriminator F6, and diodes D41 and 42.

The noise component of the detected signal is amplified by Q35 and Q36: 2SC1775(E), rectified (D44 and 45), DC amplified (Q37 and 38), then applied to squelch gate switch Q41: 2SC1815(Y), center stop control Q40: 2SC1815(Y) and BUSY LED switch Q42 and Q43: 2SC1815(Y).

The DC voltage which is generated from the discriminator (F6) is fed to window comparator Q39: NJM4558D which forms an AND circuit together with Q40 and generates the

Program Scan center stop signal which is applied to the PLL control circuit via Q46: 2SC1815(Y). The FM IF signal from Q33 is amplified by Q59: 2SC1815(Y) and detected by D39 and D40: 1N60 to drive the S meter.

In all modes other than FM, the signal which has passed F2 through F4 are amplified by Q12 and Q13: 3SK73(GR). A sample of the IF signal is buffer by Q14: 2SC1815(Y) and is AM detected by D29: 1N60, buffered by Q15, and diode switched by D30 to the squelch-controlled switch Q16. Output from Q14 is also rectified by D37 and D38: 1N60. This signal is also split: the rectified output is both AGC amplified by Q23: 2SC1815(Y) and squelch amplified by Q28: 2SC1815(Y), Q29: 2SK192A(GR), Q30: 2SA1015(Y) and Q31: 2SC1815(Y). Q24 (CW and SSB) and Q25 (AM) 2SC1815(Y) select the AGC slow time constant by mode. AGC is applied back to the RF and IF amplified. The AGC voltage is also amplified by Q50: 2SK192A(GR) and Q51: 2SA1015(Y) to drive the S meter. Q26 and Q27: 2SC1815(Y) switch off power to the AM, CW, and SSB IF amplifiers and squelch amplifiers in the FM mode. The output of the squelch amplifiers (Q31) is applied to the BUSY LED switch Q44: 2SC1815(Y), scan stop switch Q45: 2SC1815(Y) and squelch gate Q16: 2SC2240(GR). Q21: 2SC1815(Y) is the BFO circuit oscillator and Q22: 2SC1815(Y) the buffer. The BFO output is applied to the product detector D25 ~ D28 (1N60). Q20: 2SC1815(Y) is the LSB frequency shift switch.

The AM signal detected by D29 is buffered by Q15: 2SC2240(GR), and the audio signal is selected according to mode by either D30 (for AM) or D31 (for SSB and CW). This is fed through switch Q16 to audio amplifier Q17: 2SC2240(GR). The FM audio signal passes squelch gate Q52: 2SC2240(GR) and then goes to Q17.

Audio amplified by Q17 is first fed to the VOLUME and TONE controls. Q18: 2SC2240(GR) provides output to the REC jack.

The audio signal, having passed the VOLUME and TONE controls, is power amplified by Q57: HA1368R to drive the speaker.

As accessory circuits, a BEEP oscillator circuit (Q55 and 56) and standby mute circuit (Q49, 60 and 61) are provided.

In the mute mode, Q49: 2SC1815(Y) decreases the RB (receive B+) line to -6V to mute all modes except FM. The RB line then controls Q60 and 61 to disrupt FMB (FM B+) to Q33, which effectively mutes the FM mode.

The power supply circuits consists of a 9V AVR (automatic voltage regulator) Q54: AN7809 and a 14V ripple filter Q53.

| Item | Rating |
|--|--------------------------------|
| Nominal center frequency | within 9.875 MHz \pm 30 kHz |
| 3 dB bandwidth | within 130 \pm 30 kHz |
| 20 dB bandwidth | 350 kHz or less |
| Loss | 8 dB or less |
| Spurious response (within 9.875 \pm 2 MHz) (within 8.965 \pm 25 KHz) | 30 dB or more 40 dB or more |
| Input and output impedance | 330 Ω |

Table 1. Ceramic filter (L72-0338-05) RX unit F1

CIRCUIT DESCRIPTION

| Item | Rating |
|--|--------------------------------|
| Center frequency | 455 kHz \pm 0.6 kHz |
| 6 dB band width | 2.8 \pm 0.3 kHz |
| 40 dB band width | 5.5 kHz or less |
| Insertion loss (at maximum output) | 6.0 dB or less |
| Guaranteed attenuation (within 455 \pm 100 kHz) | 55 dB or more |
| Spurious attenuation (within 0.1 to 1.0 MHz) for 600 to 700 kHz. | 45 dB or more 40 dB or more |
| I/O matching impedance | 2.0 k Ω |

Table 2. Ceramic filter (L72-0332-05, RX unit F3) SSB, AM-N, CW-W

| Item | Rating |
|---|------------------------------------|
| Nominal center frequency | 455 kHz |
| 6 dB band width | \pm 3 kHz or more (from 455 kHz) |
| 50 dB band width | \pm 9 kHz or less (from 455 kHz) |
| Ripple (within 455 \pm 2 kHz) | 2 dB or less |
| Insertion loss | 6 dB or less |
| Guaranteed attenuation (within 455 \pm 100 kHz) | 60 dB or more |
| I/O matching impedance | 2.0 k Ω |

Table 3. Ceramic filter (L72-0319-05, RX unit F4) AM-W

| Item | Rating |
|---|-----------------------|
| Nominal center frequency | 455 kHz |
| 6 dB bandwidth | \pm 7.5 kHz or more |
| 50 dB bandwidth | \pm 15 kHz or less |
| Ripple (within 455 \pm 5 kHz) | 3 dB or less |
| Loss | 6 dB or less |
| Guaranteed attenuation (within 455 \pm 100 kHz) | 35 dB or more |
| Input and output impedance | 1.5 k Ω |

Table 4. Ceramic filter (L72-0316-05, RX unit F5) FM

| Item | Rating |
|----------------------------|---|
| Center frequency f_0 | 455.7 kHz |
| Center frequency deviation | $f_0 \pm 50$ Hz at 6 dB |
| 6 dB bandwidth | ± 250 Hz or more |
| 60 dB bandwidth | ± 425 Hz or less |
| Ripple | 2 dB or less |
| Loss | 6 dB or less |
| Guaranteed attenuation | 80 dB or more at 100 Hz to 455.1 kHz and 456.3 kHz to 2 MHz |
| Input and output impedance | 2 k Ω // 15 pF |

Table 5. CW Crystal filter (L71-0206-05) YG-455C (Option)

| Item | Rating |
|----------------------------|---|
| Center frequency f_0 | 455.7 kHz |
| Center frequency deviation | $f_0 \pm 50$ Hz at 6 dB |
| 6 dB bandwidth | ± 125 Hz or more |
| 60 dB bandwidth | ± 250 Hz or less |
| Ripple | 2 dB or less |
| Loss | 6 dB or less |
| Guaranteed attenuation | 80 dB or more at 100 Hz to 455.3 kHz and 456.1 kHz to 2 MHz |
| Input and output impedance | 2 k Ω // 15 pF |

Table 6. CW Crystal filter (L71-0207-05) YG-455CN (Option)

PLL (Phase locked loop) unit X50-1920-00

The PLL unit houses the PLL oscillator circuit, microprocessor control circuit and the NB amplifier circuits. In the PLL circuit, there is a 9 MHz reference frequency crystal oscillator, the first local oscillator (45.90 ~ 75.85 MHz), second local oscillator (36 MHz) and third local oscillator (9.395 ~ 9.445 MHz), which are output to the Receiver unit.

The digital circuit peripheral to the microprocessor controls the PLL circuit frequency, display, clock/timer, input interface, rotary encoder mode (speed) and memory.

1. PLL circuit

1) Reference frequency oscillator

Q1 operates at a reference frequency of 9 MHz, which is supplied to the second and third local oscillator circuits through buffer Q2.

Via buffer Q3, a 4.5 MHz signal divided 1/2 by IC1 is supplied through buffer Q4 to the first local oscillator PLL circuit. The reference frequency is also buffered (Q6) and divided down to 1 kHz by IC2 for use as a clock reference signal.

2) First local oscillator circuit (LO1)

The first local oscillator is obtained from the PLL (Phase Locked Loop) circuit. Three VCOs (Voltage Controlled Oscillator) controlled by the microprocessor through Q20 ~ 22 cover the 45.90 ~ 75.85 MHz frequency range. The VCO output is amplified by Q26, Q27 and Q28. Part of the signal is applied to buffer Q16: 2SC1907 and PLL IC5: MN6147C. The spurious component is eliminated from the remaining signal by a BPF and is output via buffer Q29 and Q30: 2SC1707 as the LO1 signal.

IC5: MN6147C consists of a programmable frequency divider, reference frequency divider and phase comparator which compares the reference and VCO frequencies (comparison frequency; 25 kHz). The programmable divider's ratio (1836 ~ 3034; only even number) is controlled by the microprocessor.

The phase error signal from the comparator is applied to the VCO by active filter Q17, Q18 and Q19: 2SC1775.

3) Second local oscillator (LO2)

The reference frequency is quadrupled by Q5: 2SC1815 to obtain the 36 MHz second local oscillation frequency.

CIRCUIT DESCRIPTION

4) Third local oscillator (LO3)

This circuit consists of PLL IC2: MN6147C which incorporates a 5 kHz PLL and mixer. One VCO is provided; the frequency range is 39.505 ~ 44.500 MHz and the dividing ratio range is 7901 ~ 8900. This PLL circuit is composed of VCO Q11: 2SC1923, PLL IC2: MN6147C and a loop filter consisting of Q8, Q9 and Q10: 2SC1775. The VCO output is buffered (Q12), divided 1/100 to 395.05 ~ 455.00 kHz by IC3: MN54459L, buffered (Q13) and mixed with the 9 MHz reference signal by IC4: SN16913P to obtain the 9.39505 ~ 9.445 MHz third local oscillator frequency. This is filtered (CF1) and amplified (Q15), then sent to the Receiver unit.

5) Unlock muting

The output from PLL IC2 pin 2 (unlock) becomes an unlock signal through IC21: TA7324P and Q71, and is used to control the audio muting circuit on Switch unit "B" to reduce or eliminate any pulse noise which may be generated when the frequency is changed and the PLL momentarily resets.

2. Control unit

1) Rotary encoder input circuit

On the Encoder unit, a 50 slit rotary disc and 2 photointerruptors generate 2 clock signals having a 90° phase difference, which are input to the Control unit via the EN1 and EN2 lines. These clock signals are waveform shaped by IC6, quadrupled by the gate circuit consisting of IC7 and 8 (the 50 pulse/rev signal is changed to a 200 pulse/rev signal), and applied IC12, through Flip-Flop IC9 1/4 to the microprocessor pin No. 39 (T1 port). At the same time, the encoder's rotational direction is detected from the clock pulses by the FF circuit IC9 1/4 and is input to microprocessor pin 29 (Port 37). The waveforms at each point are shown in Fig. 1.

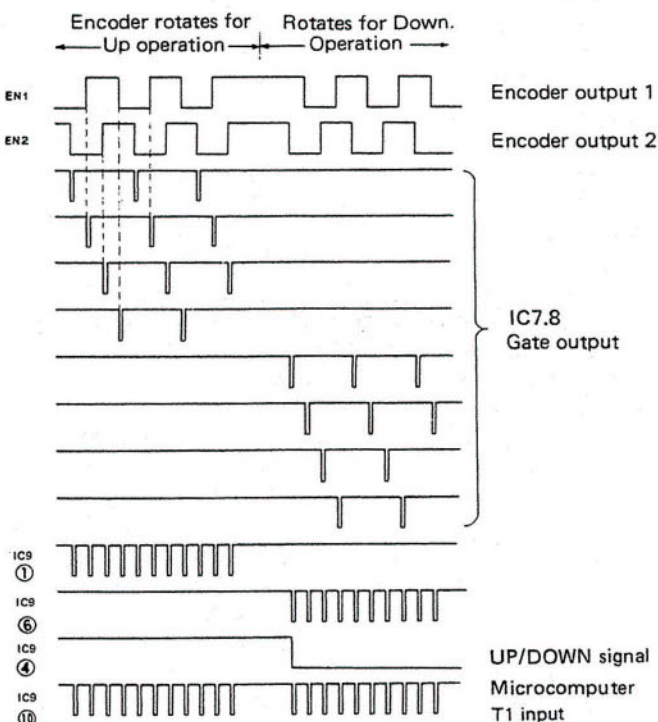

Fig. 1 Encoder output to micro-processor input timing and waveforms

2) Program scan circuit

IC10 on the Control circuit is an astable multivibrator circuit controlled by the PG. SCAN switch. Both its output, and the clock signal are applied to the microprocessor T1 port.

During scan, the multivibrator oscillators output pulse train is accessed by ICs 9 1/4, 10 1/4 and 11 1/2, while the oscillator stops in the HOLD mode and only the Encoder clock pulse is available.

The oscillator frequency is determined by C173, C174, R145 and VR1. When the tuning speed is SLOW or MID, the oscillator frequency is approximately 10 ~ 18 Hz. When it is FAST, Q34 turns on and the oscillator frequency is approximately 5 ~ 9 Hz.

3) Clock circuit

A 1 kHz clock signal is output from PLL IC2 (pin 6), waveform shaped by IC17 1/4 and applied to the microprocessor INT port (pin No. 6) to count the time.

When the HOUR and MINUTE switches are depressed simultaneously the time display shows 00:00. In CLOCK 1 mode, the time display stops flashing and the clock begins counting the seconds (which are not shown) when the switches are depressed. When the display is flashing, the HOUR and MINUTE switches cannot be used to set the time.

When the Function switch is set to any position other than FREQUENCY, depressing the HOUR switch will increment the HOUR digit by one. When the HOUR switch is held ON, the Hours digit increases continuously. The Minutes digit does not change during HOURS set.

Each time the MINUTE switch is depressed, the Minutes digit increases by one. When the switch is held ON, the Minutes digit advances. The Hours digit does not change during Minutes set.

To program the timer, set the timer ON time and place the timer switch ON. Receiver power remains off until the timer preset time is reached, when the relay is activated and the power is switched on.

When the timer OFF time is programmed, the power is turned off at that preset time. When the timer switch is ON, the power switch is inoperative. The timer relay output is available at the Remote control terminals on the rear panel.

4) Microprocessor power supply circuit

When the microprocessor IC12: μ PD80C49C is in operation, 5V should be applied to Vcc pin No. 40.

When the microprocessor is in the back-up standby mode, 2V should be applied. When the power switch is turned off, Q35 and Q36 change the level of RESET pin No. 4 to low to protect the RAM, the VDD pin No. 26 becomes low to stop the oscillator and the contents of the RAM are maintained by the low standby voltage (Vcc).

When the power is turned on, 5V is applied to the Vcc pin, the VDD pin becomes high while the RESET pin is held low to activate the oscillator, then the RESET pin returns to a logic high and the program is reset.

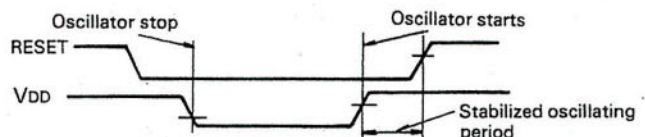

Fig. 2 Micro-processor power supply circuit

CIRCUIT DESCRIPTION

5) Dimmer circuit

The dimmer functions by controlling power to the DC/DC converter. When the main power is on, approximately 12V is supplied to Q41 and Q42 by Q61, Q72, Q73 and D40. When the main power is off or the DIMMER switch is ON, Q73 turns off, and the voltage to Q41 and Q42 is decreased to approximately 8.5V to reduce the display voltage, resulting in a dimmed display.

6) Display circuit

The seven segment and digit signals are output from IC14 to drive the 8-digit display. As the output current is active low, IC15, IC16, Q38, Q39 and Q40 are used.

3. Noise blanker circuit

Pulse noise is obtained through Q11 on the Receiver unit. It is amplified by Q62, Q63 and Q64, rectified by D43 and D44 and DC amplified by Q66 to drive the Receiver unit NB gate circuit. The NB is ON when Q66 is emitter is grounded through D45 varistor. Q65 is the NB AGC amplifier.

| Item | Rating |
|--|--------------------------------|
| Nominal center frequency | within 9.420 MHz \pm 30 kHz |
| 3 dB bandwidth | within 130 \pm 30 kHz |
| 20 dB bandwidth | 350 kHz or less |
| Loss | 8 dB or less |
| Spurious response (within 9.420 \pm 2 MHz) (within 8.510 \pm 25 KHz) | 30 dB or more 40 dB or more |
| Input and output impedance | 330 Ω |

Table 7. Ceramic filter (L72-0337-05) PLL unit CF1

Microprocessor Operational Description

1. Digital VFO

1) Reception frequency

The VFO continuously covers 100 kHz - 29,999.95 kHz and stops at the end.

W2 type: 150 kHz - 25.99995 MHz

X type : 2 MHz - 29.99995 MHz

2) Frequency step

| | Step | One VFO cycle |
|------|--------|---------------|
| FAST | 5 kHz | 1 MHz |
| MID | 500 Hz | 100 kHz |
| SLOW | 50 Hz | 10 kHz |

The step changeover frequency does not change.

When the VFO is operated with an increased step frequency, frequencies lower than the step frequency are rounded and the VFO scans up or down referring to that frequency.

Example: SLOW step \rightarrow FAST step

1

3,160.45 MHz

(3,160.4 MHz) \rightarrow 3,165.00 MHz (3,165.0 MHz) UP
3,155.00 MHz (3,155.0 MHz) DOWN

2

3,163.45 MHz

(3,163.4 MHz) \rightarrow 3,170 MHz (3,170.0 MHz) UP
3,160.00 MHz (3,160.0 MHz) DOWN

3

3,168.45 MHz

(3,168.4 MHz) \rightarrow 3,170.00 MHz (3,170.0 MHz) UP
3,160.00 MHz (3,160.0 MHz) DOWN

The above frequencies are displayed frequency; the 10 Hz digits are not displayed.

3) BAND function

The frequency changes by a 1 MHz step when the BAND switch is operated. When the switch is kept depressed, the frequency changes continuously every 0.2 seconds. A beep signal sounds every step. The BAND function stops at the frequency limit and the beep signal does not sound.

When the down operation below the receivable range, the final displayed frequency is the minimum receivable frequency.

Example:

DOWN UP
1,034.6 kHz \rightarrow 0,100.0 kHz \rightarrow 1,100.0 kHz

4) F. LOCK

The VFO and BAND switch operation stop when the F. LOCK switch is set to ON.

5) BACK UP

When the memory is not backed up, the unit enters 15,000.00 kHz MODE (AM) after initial setting.

When the memory is backed up, the unit enters the last reception frequency mode.

2. MODE function

With the mode select operation, the 1st local oscillation frequency is shifted and the displayed frequency is received.

| | 1st local oscillation frequency shift width |
|-----|---|
| AM | 0 (Reference) |
| FM | 0 |
| USB | +1.7 kHz |
| LSB | -1.7 kHz |
| CW | +0.7 kHz |

3. MEMORY function

1) Memory contents

Built-in 10-channel memory (Frequency and mode information is stored.)

2) M. IN function

When M.CH 1 - 0 switch is pressed with the M.IN switch kept pressed the selected memory channel data is displayed, the beep signal sounds and the displayed frequency and mode are stored. At that time, the previously stored data is replaced with new data.

3) MR function

When M.CH 1 - 0 is pressed, the stored memory contents are recalled to the VFO, enabling frequency shifting.

4) AUTO.M function

When the AUTO.M switch is pressed, the AUTO.M indicator lights and the auto memory function turns on.

When the switch is pressed again, the indicator goes off and the auto memory function turns off.

Auto memory ON: The shifted frequency and mode are stored in the displayed memory channel.

Auto memory OFF: The displayed memory channel contents are not changed even when the frequency is shifted or the mode is changed.

CIRCUIT DESCRIPTION

| Function | Hour | Minute | Operation |
|----------|------|--------|---|
| CLOCK-2 | ON | ON | Reset to 0:00 and the seconds digits count. |
| | ON | OFF | The minutes digits are maintained, the hours digit is incremented and the seconds digits count. |
| | OFF | ON | The hours digit is maintained, the minutes digits are incremented and the seconds digits count. |

The clock employs the 24-hour system.

0.00 ... → 23,59 → 0.00 ... → 3.15 → 3.16 ...

Each time the HOUR or MINUTE switch is pressed, the corresponding digit is incremented by 1. When the switch is kept pressed, the digit is continuously incremented at an interval of 0.12 seconds.

3) When the power is shut off, the CLOCK-1 and CLOCK-2 are reset to 0:00. When the power is supplied again, the indication blinks.

7. Timer function

1) TIMER switch

When the TIMER switch is set to ON regardless of the POWER switch setting, the power is turned off and the timer functions. The CLOCK-1 and ON TIME are compared and power is supplied when the set times coincide. Then the CLOCK-2 and OFF time are compared and power is shut off when the set times coincide.

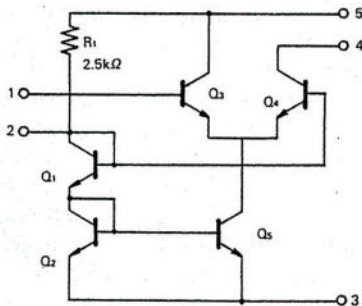

Fig. 3 TA7060P (RX unit Q32)

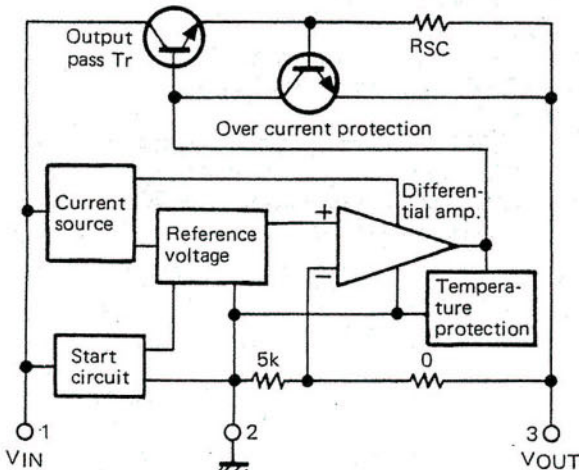

Fig. 4 AN7809 (RX unit Q54, PLL unit IC20)
AN7805 (PLL unit IC18, 19)

When the ON and OFF times are the same, the power is not turned on.

When CLOCK-1 indication blinks, setting the TIMER switch ON will not operate the timer and the TIMER ERROR indicator will light.

2) Time setting

| Function | Hour | Minute | Operation |
|----------|------|--------|---|
| ON/OFF | ON | ON | Reset to 0:00. |
| TIME | ON | OFF | The minutes digits are maintained and the hours digits are incremented. |
| | OFF | ON | The hours digit is maintained and the minutes digits are incremented. |

The HOUR and MINUTE switches function in the same way as for the clock.

3) The CLOCK and ON/OFF TIME are displayed regardless of the POWER switch setting.

8. BACK UP

When the memory back up lithium battery is loaded, the data (frequency and mode) stored in the memory, last reception frequency and mode and ON/OFF TIME are backed up even when the power is shut off.

9. Dimmer function

When the DIMMER switch is set to ON or the POWER switch is set to OFF, the brightness of the digital display and meter decreases, resulting in a dimmer effect.

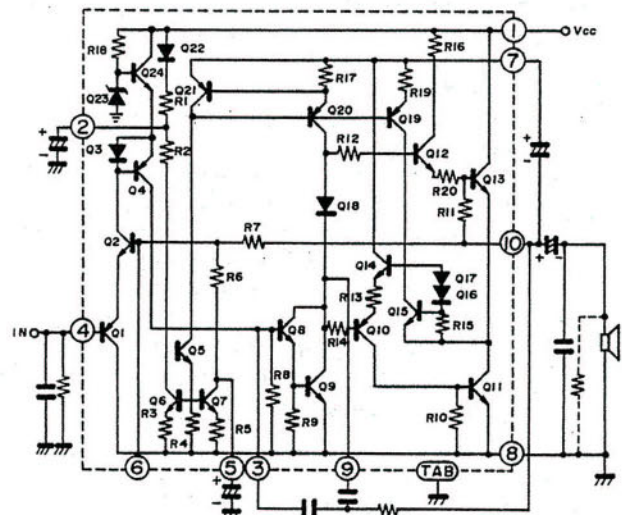
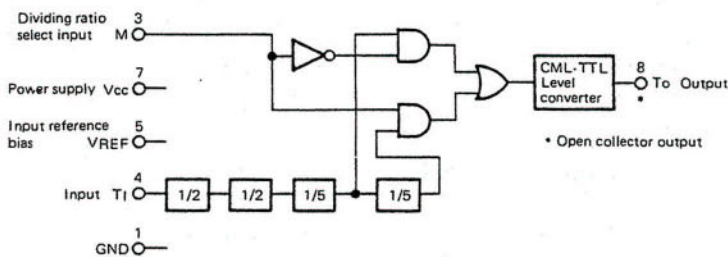
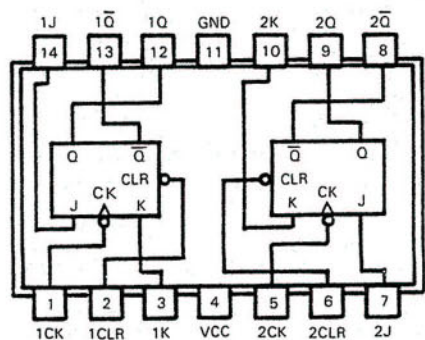

Fig. 5 HA1368R (RX unit Q57)

CIRCUIT DESCRIPTION



| | M | "L" | "H" |
|----------------------|---|------|-------|
| Dividing data output | | 1/20 | 1/100 |

Fig. 8 M54459L (PLL unit IC3)

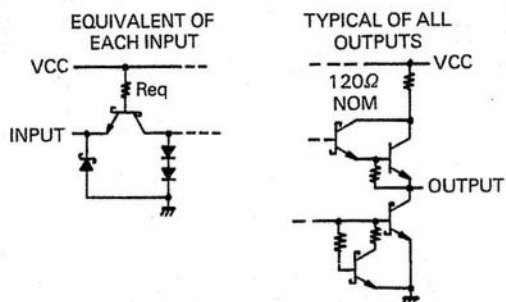
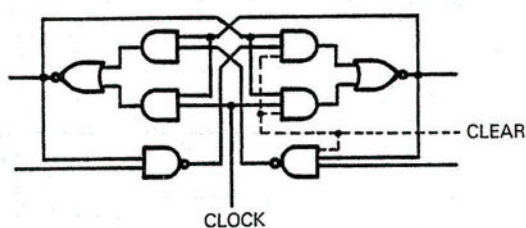

Fig. 6 SN74LS73N (PLL unit IC1)

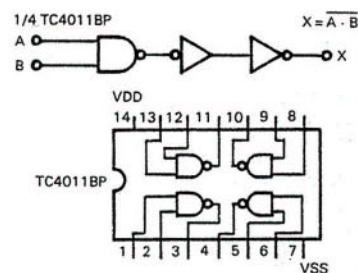

Fig. 9 TC4011BP (PLL unit IC6 ~ 11, 17)

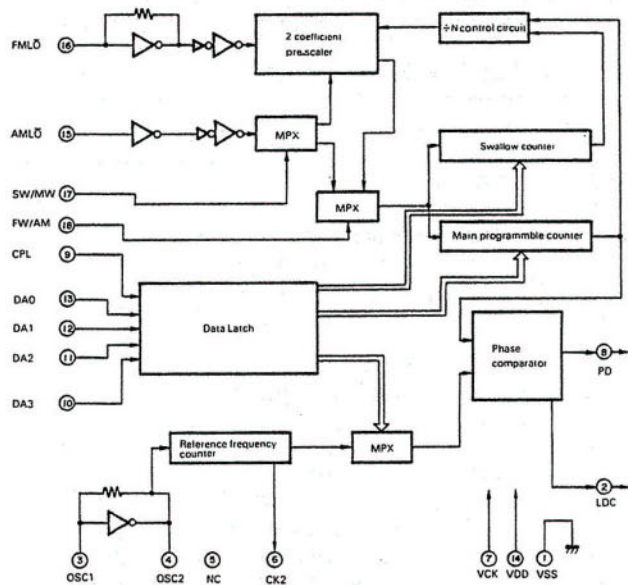

Fig. 7 MN6147C (PLL unit IC2, 5)

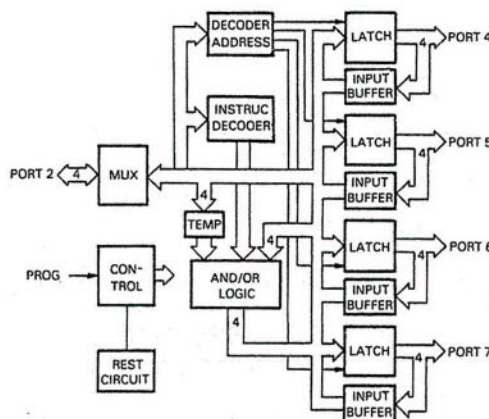

Fig. 10 μPD82C43C (PLL unit IC13, 14)

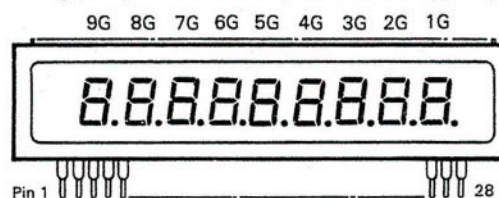

Fig. 11 FIP9D7 (PLL unit)

Table 8. FIP9D7 Terminals

| | | | | | | | | | | | | | | |
|--------------|----|----|----|----|------|----|------|------|----|------|------|----|----|----|
| Terminal No. | 1 | 2 | 3 | 4 | 5 | 6 | 7 | 8 | 9 | 10 | 11 | 12 | 13 | 14 |
| Connection | F | NC | 9G | NC | NC | 8G | P(g) | P(f) | 7G | P(e) | P(d) | 6G | NC | NC |
| Terminal No. | 15 | 16 | 17 | 18 | 19 | 20 | 21 | 22 | 23 | 24 | 25 | 26 | 27 | 28 |
| Connection | 5G | NP | NP | 4G | P(d) | 3G | P(c) | P(b) | 2G | P(a) | NC | 1G | NP | F |

CIRCUIT DESCRIPTION

| Item | Symbol | Rating | Unit |
|-----------------------|-----------|------------------------------|------|
| Operating voltage | V_{cc} | $V_{ss}-0.3 \sim +10$ | V |
| Input voltage | V_i | $V_{ss}-0.3 \sim V_{cc}+0.3$ | V |
| Output voltage | V_o | $V_{ss}-0.3 \sim V_{cc}+0.3$ | V |
| Operating temperature | T_{opt} | $-40 \sim +85$ | °C |
| Storage temperature | T_{stg} | $-65 \sim +150$ | °C |

Table 9. μ PD80C49C-022 Max. Rating

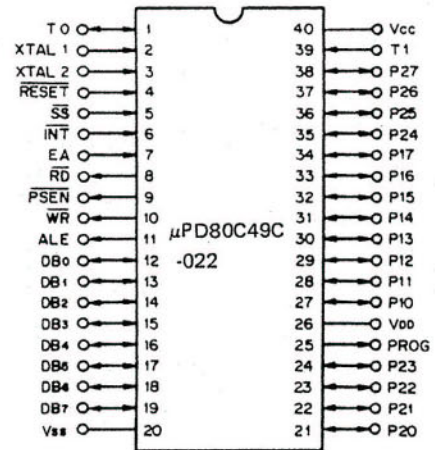

Fig. 12. μ PD80C49C-022 Terminal name

μ PD80C49C-022 TERMINAL FUNCTIONS

| Terminal No. | Name | Function | Input | Output |
|--------------|------|-------------------------------------|-------|--------|
| 1 | TO | Power ON/OFF DATA input | ○ | |
| 2 | X0 | Microcomputer CLOCK (5.74MHz) input | ○ | |
| 3 | X1 | | | |
| 4 | RST | RESET input, Normally:H | ○ | |
| 5 | SS | Normally 5V | | |
| 6 | INT | Clock signal (1KHz) input | ○ | |
| 7 | EA | Normally GND | | |
| 8 | | Not used, Normally:open | | |
| 9 | | | | |
| 10 | | | | |
| 11 | | | | |
| 12 | B0 | AM | ○ | |
| 13 | B1 | USB | ○ | |
| 14 | B2 | LSB | ○ | |
| 15 | B3 | CW | ○ | |
| 16 | B4 | FM | ○ | |
| 17 | B5 | VCO-L | ○ | |
| 18 | B6 | VCO-M | ○ | |
| 19 | B7 | VCO-H | ○ | |
| 20 | GND | GND | | |

| Terminal No. | Name | Function | Input | Output |
|--------------|------|--|-------|--------|
| 21 | P20 | I/O EXPANDER control output | | ○ |
| 22 | P21 | | | ○ |
| 23 | P22 | | | ○ |
| 24 | P23 | | | ○ |
| 25 | PRG | STBY control input | ○ | |
| 26 | VDD | | | |
| 27 | P10 | DATA input | ○ | |
| 28 | P11 | | | |
| 29 | P12 | | | |
| 30 | P13 | | ○ | |
| 31 | P14 | | ○ | |
| 32 | P15 | | ○ | |
| 33 | P16 | | ○ | |
| 34 | P17 | Program SCAN stop input | ○ | |
| 35 | P24 | I/O EXPANDER SELECT (L:EX(O), H:EX(1)) | | |
| 36 | P25 | TIMER OUT output | | ○ |
| 37 | P26 | Encoder UP/DOWN input (H:UP, L:Down) | ○ | |
| 38 | P27 | VHF signal output (VHF:H) | | ○ |
| 39 | T1 | Encoder & program SCAN clock pulse input | ○ | |
| 40 | Vcc | Microcomputer 5V & Back up power supply | | |

I/O EXPANDER (0) IC13: μ PD82C43C

| Terminal No. | Name | Function |
|--------------|------|--|
| 2 | P40 | B.P.F. Data (BCD) |
| 3 | P41 | |
| 4 | P42 | |
| 5 | P43 | |
| 1 | P50 | PLL dividing ratio data, address output & DATA SELECTOR output |
| 23 | P51 | |
| 22 | P52 | |
| 21 | P53 | |
| 20 | P60 | PLL IC5 } Latch clock output |
| 19 | P61 | |
| 18 | P62 | Beep output |
| 17 | P63 | TIMER error |
| 13 | P70 | M. SCAN |
| 14 | P71 | PG. SCAN |
| 15 | P72 | HOLD |
| 16 | P73 | AUTO. M |

I/O EXPANDER (1) IC14: μ PD82C43C

| Terminal No. | Name | Function |
|--------------|------|------------------------------|
| 2 | P40 | Display DIGIT output 100HZ |
| 3 | P41 | Display DIGIT output 1K |
| 4 | P42 | Display DIGIT output 10K |
| 5 | P43 | Display DIGIT output 100K |
| 1 | P50 | Display DIGIT output 1M |
| 23 | P51 | Display DIGIT output 10M |
| 22 | P52 | Display DIGIT output 100M |
| 21 | P53 | Display DIGIT output CH |
| 20 | P60 | Display SEGMENT output a |
| 19 | P61 | Display SEGMENT output b |
| 18 | P62 | Display SEGMENT output c |
| 17 | P63 | Display SEGMENT output d |
| 13 | P70 | Display SEGMENT output e |
| 14 | P71 | Display SEGMENT output f |
| 15 | P72 | Display SEGMENT output g |
| 16 | P73 | Display SEGMENT output point |

PARTS LIST

CAPACITORS

$\frac{CC}{1} \frac{45}{2} \frac{TH}{3} \frac{1H}{4} \frac{220}{5} \frac{J}{6}$

- 1 = Type ceramic, electrolytic, etc. 4 = Voltage rating
 2 = Shape round, square, etc. 5 = Value
 3 = Temp coefficient 6 = Tolerance

● Temperature coefficient

| 1st Word | C | I | P | R | S | T | U |
|----------|-------|-----|--------|--------|-------|------|--------|
| Color ※ | Black | Red | Orange | Yellow | Green | Blue | Violet |
| ppm /°C | 0 | -80 | -150 | -220 | -330 | -470 | -750 |

| 2nd Word | G | H | J | K | L |
|----------|-----|-----|------|------|------|
| ppm /°C | ±30 | ±60 | ±120 | ±250 | ±500 |

Example CC45TH = -470 ± 60ppm /°C

● Tolerance

| Cord | C | D | G | J | K | M | X | Z | P | No cord | Less than 10 pF |
|------|-------|------|----|----|-----|-----|------------|------------|------------|---|--|
| (%) | ±0.25 | ±0.5 | ±2 | ±5 | ±10 | ±20 | +40 -20 | +80 -20 | +100 -0 | More than 10μF -10 ~ +50 Less than 4.7μF -10 ~ +75 | Cord (pF) ±0.1 ±0.25 ±0.5 ±1 ±2 |

Resistors not listed in this parts list are standard, fixed carbon composition, 1/4W or 1/8W.

The resistance values, in ohms, are indicated on the schematic diagram.

SEMI CONDUCTOR

| Item | Name | Re-marks |
|--------|-------------|----------|
| Diode | 1N60 | |
| | 1N4448 | |
| | 1S1007 | |
| | 1S1555 | |
| | 1S1587 | |
| | 1S2588 | |
| | BA282 | |
| | D33A | |
| | RD4.7EB3 | |
| | V03C | |
| | Zener-Diode | WZ-061 |
| WZ-071 | | |
| WZ-110 | | |
| XZ-060 | | |
| LED | ON1110 | |
| | LM358P | |
| | SG238D | |
| | SR538D | |
| | SY438D | |
| | TLG205 | |
| | TLR205 | |

| Item | Name | Re-marks |
|------|-------------|----------|
| TR | TLY205 | |
| | 2SA1015(Y) | |
| | 2SC1675(L) | |
| | 2SC1775(E) | |
| | 2SC1815(Y) | |
| | 2SC1907 | |
| | 2SC1923(D) | |
| | 2SC1959(Y) | |
| | 2SC2240(GR) | |
| | 2SC2878 | N |
| | 2SD235(Y) | |
| FET | 2SK192A(GR) | |
| | 3SK73(GR) | |
| | 3SK74(L) | |
| IC | AN7805 | N |
| | AN7809 | N |
| | HA1368R | |
| | M54459L | |
| | MN6147C | |
| | NJM4558D | |

| Item | Name | Re-marks |
|----------------|---------------|----------|
| | SN16913P | |
| | SN74LS145N | |
| | SN74LS73N | |
| | TA7060AP | |
| | TA7324P | |
| | TC4011BP | |
| | TC5065BP | |
| | TC5067BP | |
| | μPC577H | |
| | μPD80C49C-022 | N |
| | μPD82C43C | N |
| Varistor | MV-13 | |
| Vari-cap | 1SV53A | |
| | 1SV54GC | |
| Display tube | FIP9D7 | |
| Surge-Absorber | ERZD03DK331 | |

N: New Parts

● Rating voltage

| 2nd word / 1st word | A | B | C | D | E | F | G | H | J | K | V |
|---------------------|------|------|------|------|------|------|------|------|------|------|----|
| 0 | 1.0 | 1.25 | 1.6 | 2.0 | 2.5 | 3.15 | 4.0 | 5.0 | 6.3 | 8.0 | - |
| 1 | 10 | 12.5 | 16 | 20 | 25 | 31.5 | 40 | 50 | 63 | 80 | 35 |
| 2 | 100 | 125 | 160 | 200 | 250 | 315 | 400 | 500 | 630 | 800 | - |
| 3 | 1000 | 1250 | 1600 | 2000 | 2500 | 3150 | 4000 | 5000 | 6300 | 8000 | - |

● Capacitor value

0 1 0 = 1pF

1 0 0 = 10pF

1 0 1 = 100pF

1 0 2 = 1000pF = 0.001μF

1 0 3 = 0.01μF

$\frac{2}{1st\ number} \frac{2}{2nd\ number} \frac{0}{Multiplier} = 22pF$

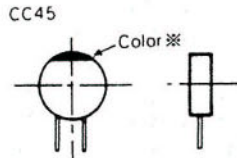

PARTS LIST

| Part No. | Re- marks | Description | Part No. | Re- marks | Description |
|----------------|--------------|-----------------------------------|-------------|--------------|---------------------------------------|
| GENERAL | | | | | |
| A01-0939-02 | N | Case (upper) | J61-0019-05 | | Band x 3 |
| A01-0940-02 | N | Case (lower) | J61-0401-05 | | Nylon band x 20 |
| A20-2465-03 | N | Panel | K01-0411-05 | N | Carring handle |
| A23-1472-02 | N | Rear panel | K21-0769-04 | N | Main knob |
| B03-0529-04 | N | Carring handle back plate | K23-0738-04 | | Knob, FUNCTION |
| B03-0530-14 | N | Switch name plate, NAR-WIDE | K23-0755-04 | N | Knob x 4, AF, TONE, SQL, ATT |
| B03-0531-04 | N | Ornamental plate, Meter | K27-0426-14 | | Band knob x 2 |
| B30-0817-15 | | Lamp, 14V 80mA | K29-0758-04 | | Push knob x 2, POWER, TIMER |
| B31-0641-05 | N | Meter | K29-0767-04 | | Push knob x 2, DIM, NB |
| B39-0407-04 | | Spacer x2 | K29-0768-04 | | Push knob, AGC |
| B42-1722-24 | | FTZ plate | K29-0771-04 | | Knob ring |
| B43-0686-04 | N | Badge | K29-0772-03 | N | Knob ass'y |
| B43-0687-04 | N | Badge | K29-0773-04 | N | Push knob, MODE |
| B46-0058-10 | | Warranty card (TKC) | K29-0774-04 | N | Push knob, NAR-WIDE |
| B50-4022-00 | N | Instruction manual | K29-0775-04 | N | Push knob, F. LOCK |
| B50-4023-00 | N | Instruction manual | K29-0776-04 | N | Push knob x 3, TUNING SPEED |
| B58-0637-00 | | Voltage warning paper | L01-8064-05 | N | Power transformer |
| B58-0638-00 | | Warning paper | N09-0256-05 | | Ground screw, ANT |
| B58-0653-00 | N | Warning paper | N09-0641-05 | | Screw x 7, Panel |
| B58-0654-00 | N | Warning paper | N14-0508-04 | | Spanner nut, Panel |
| C91-0079-05 | | C, 0.01 AC125V | N15-1040-46 | | Washer x 2, Carring handle |
| E04-0152-05 | | UHF type receptacle, ANT | N30-2608-41 | | Screw x 2, DC |
| E07-0751-05 | | 7P DIN plug, accessory | N30-3006-41 | | Screw x 7, Lamp, PLL, DIN |
| E12-0001-15 | | Phone plug, accessory | N30-3008-41 | | Screw x 2, AC |
| E18-0351-05 | | 3P Inlet, AC power | N30-3012-46 | | Screw, Panel |
| E30-1643-15 | | AC Cable ass'y | N30-4006-46 | | Screw x 2, Carring handle |
| E30-1644-15 | | AC Cable ass'y | N32-2606-46 | | Flat screw x 4, Meter |
| E30-1645-05 | | AC Cable ass'y | N35-3006-41 | | Bind screw x 16, Case |
| E30-1647-05 | | AC Cable ass'y | N87-2606-46 | | Bind tapping screw x16 |
| F05-1013-05 | | Fuse x 2, 0.1A, accessory | N87-2608-46 | | Self tapping screw x5 |
| F05-1521-05 | | Fuse 1.5A, accessory | N87-3006-41 | | Knob ass'y x 5 |
| F15-0646-04 | N | Switch mask, Piano switch | N87-3008-41 | | Self tapping screw x 25 |
| F19-0610-04 | | Connector mask, DC13.8V | N87-3010-46 | | Push switch, etc |
| F19-0622-04 | N | Rear cover | N87-3012-46 | | Self tapping screw x 2, ANT, SP |
| G13-0669-04 | | Cushion, MODE | N87-3012-46 | | Self tapping screw x 3, SP |
| G16-0506-04 | | Anti vibration sheet, Case | N88-3006-46 | | Tap tight screw x 24, PC board |
| G53-0510-04 | | Packing x 2, Case | S90-0405-05 | N | Tap tight screw x 10, Sub panel, etc. |
| H01-4463-04 | N | Packing carton | T07-0225-15 | N | Rotary remote switch, ATT |
| H01-4464-04 | N | packing carton | X41-1480-00 | N | Speaker |
| H03-2098-04 | N | Packing carton | X41-1480-61 | N | Switch unit |
| H10-2569-02 | N | Packing fixture (R) | X41-1480-71 | N | Switch unit |
| H10-2570-02 | N | Packing fixture (L) | X50-1920-00 | N | PLL unit |
| H12-1320-04 | N | Cushion | X54-1690-00 | | Encoder unit |
| H20-1419-03 | N | Protective cover | X55-1340-00 | N | RX unit |
| H25-0029-04 | | Protective bag 60x100 | | | |
| H25-0105-04 | | Protective bag 150x350 | | | |
| J02-0323-05 | | Foot x 4, Case (lower) | | | |
| J02-0403-04 | | Rubber foot x 4, Case | | | |
| J02-0428-05 | N | Assistant foot, Case (lower) | | | |
| J19-1369-04 | N | Knob metal fittings, Piano switch | | | |
| J19-1372-14 | N | Knob metal fittings, Piano switch | | | |
| J21-2573-04 | | Foot metal fittings x 2, Case | | | |
| J21-2788-04 | N | Speaker metal fittings x 3 | | | |
| J32-0767-04 | N | Hex. boss x 4, Meter | | | |

PARTS LIST

| Part No. | Re- marks | Description | Ref. No. | Q'ty | Part No. | Re- marks | Description | Ref. No. | Q'ty |
|----------------------------------|--------------|-----------------------------|---|------|---|--------------|---------------------------|--|------|
| SWITCH UNIT (X41-1480-00) | | | | | -00: K, M, T, W -61: W₂, -71: X | | | | |
| CE04W1C100M | | E, 10 16V | C8 | 1 | CC45CH1H150J | | C, 15P | C52,76,150 | 3 |
| CE04W1H4R7M | | E, 4.7 50V | C2,4 | 2 | CC45CH1H220J | | C, 22P | C14,155 | 2 |
| CQ92M1H102K | | ML, 0.001 | C5 | 1 | CC45RH1H010C | | C, 1P ±0.25P | C135 | 1 |
| CQ92M1H104K | | ML, 0.1 | C1,13 | 2 | CC45RH1H020C | | C, 2P ±0.25P | C133,142 | 2 |
| CQ92M1H683K | | ML, 0.068 | C3 | 1 | CC45RH1H040C | | C, 4P ±0.25P | C138 | 1 |
| CK45F1H103Z | | C, 0.01 | C6,7,9,12 | 4 | CC45RH1H060D | | C, 6P ±0.5P | C140,143,146 | 3 |
| CK45F1H473Z | | C, 0.047 | C21,23,24 | 3 | CC45RH1H070D | | C, 7P ±0.5P | C51 | 1 |
| C90-0814-05 | | C, 4700 25V | C22 | 1 | CC45RH1H100D | | C, 10P ±0.5P | C115,120,125 | 3 |
| E11-0413-05 | | US jack, phones | | 1 | CC45RH1H220J | | C, 22P | C144, | 1 |
| E11-0414-05 | N | US jack, REC | | 1 | CC45RH1H330J | | C, 33P | C141 | 1 |
| E23-0512-05 | | Terminal | | 2 | CC45RH1H470J | | C, 47P | C49, 118 | 2 |
| E40-0273-05 | | Mini connector 2P | | 2 | CC45RH1H560J | | C, 56P | C113 | 1 |
| E40-0442-05 | | Power connector (4P) | | 1 | CC45SL1H101J | | C, 100P | C13,16,26 | 3 |
| F05-1521-05 | | Fuse, 1.5A | | 1 | CC45SL1H121J | | C, 120P | C147 | 1 |
| J13-0401-05 | | Fuse holder | | 2 | CC45SL1H180J | | C, 18P | C181,182 | 2 |
| J30-0514-14 | | LED spacer | | 6 | CC45SL1H181J | | C, 180P | C68 | 1 |
| R01-3421-05 | | Pot. 10KΩ (A), AF, tone | VR1,2 | 2 | CC45SL1H330J | | C, 33P | C11 | 1 |
| R06-9406-05 | N | Pot. 50KΩ (B), 10KΩ (B) SQL | VR3, | 1 | CC45SL1H560J | | C, 56P | C65,67,112 | 3 |
| RS14AB3A220J | | Metal film 22Ω ±5% 1W | R12 | 1 | CE04W1A101M | | E, 100 10V | C175, | 1 |
| RS14AB3A470J | | Metal film 47Ω ±5% 1W | R11 | 1 | CE04W1A470M | | E, 47 10V | C177,185 | 2 |
| R92-0150-05 | | Jumper wire | | 25 | CE04W1C101M | | E, 100 16V | C222 | 1 |
| S29-1429-05 | N | Rotary switch, FUNCTION | S30 | 1 | CE04W1C220M | | E, 22 16V | C18,47,55,97, 100 | 5 |
| S29-1430-05 | N | Voltage select switch | S40 | 1 | CE04W1C221M | | E, 220 16V | C186 | 1 |
| S40-2440-15 | | Push switch, NB, DIM, AGC | S27~29 | 3 | CE04W1E100M | | E, 10 25V | C187,189 | 2 |
| S40-2442-05 | N | Push switch, NAR-WIDE | S24 | 1 | CE04W1E470M | | E, 47 25V | C213,217 | 2 |
| S42-2406-05 | N | Push switch, power, timer | S31 | 1 | CE04W1H0R1M | | E, 0.1 50V | C180, | 1 |
| S42-4402-05 | N | Push switch, tuning speed | S23 | 1 | CE04W1H010M | | E, 1 50V | C178,231 | 2 |
| S50-1409-05 | | Tact switch, BAND | S25,26 | 2 | CE04W1H100M | | E, 10 50V | C190,191 | 2 |
| S50-1411-05 | | Tact switch, MODE | S16~20 | 5 | CE04W1HR47M | | E, 0.47 50V | C227,230 | 2 |
| S50-1412-05 | N | Tact switch | S1~15,21,22 | 17 | CE04W1H4R7M | | E, 4.7 50V | C201 | 1 |
| PLL UNIT (X50-1920-00) | | | | | | | | | |
| C05-0013-15 | | Ceramic trimmer 30pF | C1 | 1 | CK45B1H102K | | C, 0.001 | C40,60,64,66,70,79,80,82, 90,148,153,157,~159,166, 172,198,202,234,236 | 23 |
| CC45CH1H010C | | C, 1P ±0.25P | C75, | 1 | CK45B1H221K | | C, 220P | C12 | 1 |
| CC45CH1H030C | | C, 3P ±0.25P | C88 | 1 | CK45F1H103Z | | C, 0.01 | C25,36,54,63,98,99,111, 131,132,137,149,152, 156,160,188,203,211, 235 | 18 |
| CC45CH1H050C | | C, 5P ±0.25P | C15,22,37,38, 57,58,87,154 | 8 | CK45F1H223Z | | C, 0.022 | C24,28,29,39,56,59,74,83, 84,85,89,129,193~197, 204~210,237 | 27 |
| CC45CH1H0R5C | | C, 0.5P ±0.25P | C31,134,136 | 3 | CK45F1H473Z | | C, 0.047 | C21,35,41,42,61,62,69,77, 91,167,170,176,179,184 199,212,216,224,225,228 232, 238 | 22 |
| CC45CH1H100D | | C, 10P ±0.5P | C23,33,53, 117,121,122, 126,127,151 | 9 | CQ92M1H103K | | ML, 0.01 | C92,93 | 2 |
| CC45CH1H120J | | C, 12P | C116 | 1 | CQ92M1H104K | | ML, 0.1 | C45,95,214, 215,218~ 221 | 8 |
| | | | | | CQ92M1H123K | | ML, 0.012 | C43,44,94, | 3 |
| | | | | | CQ92M1H333K | | ML, 0.033 | C173,174 | 2 |
| | | | | | CQ92M1H472K | | ML, 0.0047 | C48,128 | 2 |
| | | | | | C90-0817-05 | | C, 1000 16V | C130 | 1 |
| | | | | | C91-0456-05 | | E, 0.047 25V | C19,46,71~73,96,162,168, 169,171,183,192,200, 223,226,229 | 16 |
| | | | | | E04-0154-05 | | Coax connector | | 4 |
| | | | | | E06-0752-05 | N | DIN connector, 7P, REMOTE | | 1 |

PARTS LIST

| Part No. | Re- marks | Description | Ref. No. | Q'ty | Part No. | Re- marks | Description | Ref. No. | Q'ty |
|--------------|--------------|------------------------------|------------------------|------|-----------------------------------|--------------|-------------------|---|------|
| E06-1051-05 | N | DIN connector, 10P | | 1 | S51-2408-05 | | Relay | RL1 | 1 |
| E11-0408-05 | | V. CONVERTER | | 1 | W09-0323-05 | | Lithium battery | | 1 |
| E23-0046-04 | | MIC jack, EXT SP | | 2 | ENCODER UNIT (X54-1690-00) | | | | |
| E40-0273-05 | | Square terminal | | 2 | CE04W0J101M | | E, 100 6.3V | C1 | 1 |
| E40-0273-05 | | Mini connector, 2P | | 12 | D09-0305-04 | | Encoder slit | | 1 |
| E40-0373-05 | | Mini connector, 3P | | 3 | D21-0824-05 | | Shaft ass'y | | 1 |
| E40-0473-05 | | Mini connector, 4P | | 4 | N30-2606-46 | | Screw | | 2 |
| E40-0573-05 | | Mini connector, 5P | | 3 | R12-2409-05 | | Trim. pot 5kΩ (B) | VR1,2 | 2 |
| E40-0673-05 | | Mini connector, 6P | | 1 | RX UNIT (X55-1340-00) | | | | |
| E40-0773-05 | | Mini connector, 7P | | 1 | CC45CG1H221J | | C, 220P | C165 | 1 |
| J21-2792-04 | | Connector metal fittings (B) | | 1 | CC45CH1H020C | | C, 2P ±0.25P | C110 | 1 |
| J31-0502-04 | | PC Board collar | | 9 | CC45CH1H050C | | C, 5P ±0.25P | C93 | 1 |
| J42-0428-05 | | PC Board bush | | 9 | CC45CH1H0R5C | | C, 0.5P ±0.25P | C95 | 1 |
| L19-0323-05 | | OSC transformer DC-DC | T9 | 1 | CC45CH1H070D | | C, 7P ±0.5P | C96 | 1 |
| L32-0651-05 | | OSC coil VCO-L | T6 | 1 | CC45CH1H150J | | C, 15P | C111 | 1 |
| L32-0652-05 | | OSC coil VCO-M | T7 | 1 | CC45CH1H151J | | C, 150P | C175 | 1 |
| L32-0653-05 | | OSC coil VCO-H | T8 | 1 | CC45CH1H220J | | C, 22P | C188 | 1 |
| L34-0540-05 | | Tuning coil 455KHz | T10 | 1 | CC45CH1H270J | | C, 27P | C164 | 1 |
| L34-0863-05 | | Tuning coil 455KHz | T11 | 1 | CC45CH1H330J | | C, 33P | C169 | 1 |
| L34-2058-05 | | Tuning coil VCO | T3 | 1 | CC45RH1H020C | | C, 2P ±0.25P | C80 | 1 |
| L34-2147-05 | N | Tuning coil 9.42MHz | T4 | 1 | CC45RH1H070D | | C, 7P ±0.5P | C90 | 1 |
| L34-2148-05 | N | Tuning coil 9.42MHz | T5 | 1 | CC45SL1H101J | | C, 100P | C141,144 | 2 |
| L34-2149-05 | N | Tuning coil 36MHz | T1,2 | 2 | CC45SL1H120J | | C, 12P | C234,235 | 2 |
| L40-1001-03 | | Ferri-inductor 10μH | L22,39 | 2 | CC45SL1H151J | | C, 150P | C29,31,36,37,67 | 5 |
| L40-1001-14 | | Ferri-inductor 10μH | L67,68 | 2 | CC45SL1H220J | | C, 22P | C205,207 | 2 |
| L40-1011-03 | | Ferri-inductor 100μH | L6,11,19,40~44 | 15 | CC45SL1H241J | | C, 240P | C27~29 | 3 |
| L40-1011-13 | | Ferri-inductor 100μH | L58,66 | 2 | CC45SL1H270J | | C, 27P | C109 | 1 |
| L40-1011-14 | | Ferri-inductor 100μH | L51~56 | 6 | CC45SL1H301J | | C, 300P | C30 | 1 |
| L40-1021-03 | | Ferri-inductor 1mH | L7~9,12,20,23,27,59,60 | 9 | CC45SL1H331J | | C, 330P | C19,21 | 2 |
| L40-1092-14 | | Ferri-inductor 1μH | L32 | 1 | CC45SL1H511J | | C, 510P | C16~18 | 3 |
| L40-1292-14 | | Ferri-inductor 1.2μH | L29,31,34 | 3 | CC45SL1H680J | | C, 68P | C38 | 1 |
| L40-1501-03 | | Ferri-inductor 15μH | L26 | 1 | CC45SL1H820J | | C, 82P | C40,170,243 | 3 |
| L40-1511-03 | | Ferri-inductor 150μH | L13,15,45 | 3 | CE04W1A101M | | E, 100 10V | C233,247 | 2 |
| L40-1541-27 | | Ferri-inductor 150μH | L21, | 1 | CE04W1A470M | | E, 47 10V | C156,158,160,226,231,237,251,252 | 8 |
| L40-1801-03 | | Ferri-inductor 18μH | L25, | 1 | CE04W1C100M | | E, 10 16V | C11,15,22,26,32,35,41,44,51,54,60,63,64,71,76,78,83,112,117~119,123~130,147,148,150,176,181,210,212,214,228,240 | 39 |
| L40-1892-14 | | Ferri-inductor 1.8μH | L30, | 1 | CE04W1C101M | | E, 100 16V | C217, | 1 |
| L40-2201-03 | | Ferri-inductor 22μH | L24,37,38, | 3 | CE04W1C102M | | E, 1000 16V | C238 | 1 |
| L40-2211-03 | | Ferri-inductor 220μH | L16 | 1 | CE04W1C221M | | E, 220 16V | C218, | 1 |
| L40-2225-04 | | Ferri-inductor 2.2mH | L14, | 1 | CE04W1H0R1M | | E, 0.1 50V | C149, | 1 |
| L40-2282-14 | | Ferri-inductor 0.22μH | L33,36 | 2 | CE04W1H010M | | E, 1 50V | C3,69 | 8 |
| L40-3982-14 | | Ferri-inductor 0.39μH | L35, | 1 | CE04W1HR22M | | E, 0.22 50V | 155,157,159,172,197,255 | 3 |
| L40-4701-03 | | Ferri-inductor 47μH | L10,28 | 2 | | | | C182,183,215 | |
| L40-4711-03 | | Ferri-inductor 470μH | L1~5,17,18 | 7 | | | | | |
| L72-0337-05 | N | Ceramic filter 9.42MHz | CF1 | 1 | | | | | |
| L77-0984-05 | N | Crystal 9MHz | X1 | 1 | | | | | |
| L78-0005-05 | | Ceramic oscillator 5.745MHz | X2 | 1 | | | | | |
| N09-0641-05 | | Screw | | 2 | | | | | |
| N10-2030-46 | | Screw | | 2 | | | | | |
| N30-2606-46 | | Screw | | 6 | | | | | |
| N30-3006-46 | | Screw | | 1 | | | | | |
| N30-3008-46 | | Screw | | 2 | | | | | |
| R12-6401-05 | | Trim. pot 470K (B) | VR1 | 1 | | | | | |
| RS14AB3D101J | | Metal film 100Ω ±5% 2W | R217 | 1 | | | | | |
| RS14AB3D150J | | Metal film 15Ω ±5% 2W | R218, | 1 | | | | | |
| R90-0162-05 | | Inline block 47kΩ × 8 | IB2~4 | 3 | | | | | |
| R92-0563-05 | | Inline block 150kΩ × 5 | IB5,6 | 2 | | | | | |
| R92-0150-05 | | Short jumper | | 191 | | | | | |

PARTS LIST

| Part No. | Re- marks | Description | Ref. No. | Q'ty | Part No. | Re- marks | Description | Ref. No. | Q'ty |
|--------------|--------------|-----------------------------|--|------|-------------|--------------|----------------------------------|-------------------------|------|
| CE04W1H2R2M | | E, 2.2 50V | C152,178,179 | 3 | L34-0858-05 | | Tuning coil 46MHz | T5 | 1 |
| CE04W1H3R3M | | E, 3.3 50V | C209 | 1 | L34-0864-05 | | Tuning coil 455KHz | T14 | 1 |
| CE04W1HR47M | | E, 0.47 50V | C146,151,153, 180 | 4 | L34-0865-15 | | Tuning coil 455KHz | T15 | 1 |
| CE04W1H4R7M | | E, 4.7 50V | C211, | 1 | L34-0866-15 | | Tuning coil 455KHz | T16 | 1 |
| CK45B1H102K | | C, 0.001 | C87,94,100 107,196,245 | 6 | L34-0868-05 | | Tuning coil 455KHz | T18 | 1 |
| CK45B1H681K | | C, 680P | C8,10,20 | 3 | L34-2068-05 | | Tuning coil 46MHz | T6,7 | 2 |
| CK45F1H103Z | | C, 0.01 | C73,92,98,113,115,116, 121,122,131,136,163, 171,186,221,232,241 | 16 | L34-2109-15 | | Tuning coil 46MHz | T3 | 1 |
| CQ92M1H102K | | ML, 0.001 | C5 ~ 7,168, 200,254 | 6 | L34-2148-05 | | Tuning coil 9.42MHz | T13 | 1 |
| CQ92M1H103K | | ML, 0.01 | C206,222 ~ 225 | 5 | L34-2149-05 | | Tuning coil 36MHz | T9 | 1 |
| CQ92M1H104K | | ML, 0.1 | C219,220, 239,253 | 4 | L34-2150-05 | N | Tuning coil 46 MHz | T8 | 1 |
| CQ92M1H122K | | ML, 0.0012 | C9,48,50 | 3 | L34-2151-05 | N | Tuning coil 9.9MHz | T10 | 1 |
| CQ92M1H183K | | ML, 0.018 | C201, | 1 | L34-2152-05 | N | Tuning coil 9.9MHz | T12 | 1 |
| CQ92M1H222K | | ML, 0.0022 | C47,202,204, 208 | 4 | L34-2153-05 | N | Tuning coil 9.9MHz | T11 | 1 |
| CQ92M1H272K | | ML, 0.0027 | C49,57,59, | 3 | L40-1001-02 | | Ferri-inductor 10μH | L24,26 | 2 |
| CQ92M1H333K | | ML, 0.033 | C55,56,167, 173,174 | 5 | L40-1011-03 | | Ferri-inductor 100μH | L41,42,44,45, | 4 |
| CQ92M1H392K | | ML, 0.0039 | C45,46,230 | 3 | L40-1021-03 | | Ferri-inductor 1mH | L39,40,46 ~ 48,51,52 | 7 |
| CQ92M1H393K | | ML, 0.039 | C203 | 1 | L40-1205-25 | | Ferri-inductor 12μH | L31,32 | 2 |
| CQ92M1H473K | | ML, 0.047 | C199,213,229 | 3 | L40-1092-02 | | Ferri-inductor 1μH | L54 | 1 |
| CQ92M1H562K | | ML, 0.0056 | C58 | 1 | L40-1092-02 | | Ferri-inductor 1.2μH | L9,10,14,16 | 4 |
| CQ09FS1H561G | | ML, 560P ± 2% | C166 | 1 | L40-1892-02 | | Ferri-inductor 1.8μH | L12,13, | 2 |
| C90-0817-05 | | E, 1000 16V | C236 | 1 | L40-2282-14 | | Ferri-inductor 0.22μH | L20 | 1 |
| C91-0131-05 | | C, 0.01 25V | C4,65,70,81,84,97,99,101, 102,143,145,154,189, 216,227 | 15 | L40-2791-02 | | Ferri-inductor 2.7μH | L3,4,8,11 | 4 |
| C91-0456-05 | | C, 0.047 25V | C82,248,249,12 ~ 14,23 ~ 25,33,34,42,43,52,53,61, 62,72,74,75,77,79,85,86, 91,103, ~ 106,108,114, 120,132, ~ 135,137 ~ 140,142,177,184,185,187, 190 ~ 195,198,66,88,89, 244,246 | 1 | L40-3382-14 | | Ferri-inductor 0.33μH | L36, | 1 |
| C91-0490-05 | | Cap, 1000P 50V | C242 | 1 | L40-3392-02 | | Ferri-inductor 3.3μH | L6,7 | 2 |
| E04-0154-05 | | Coax connector | | 1 | L40-3982-14 | | Ferri-inductor 0.39μH | L22,23 | 2 |
| E04-0157-05 | | Mini pin jack A | | 3 | L40-3991-02 | | Ferri-inductor 3.9μH | L38 | 1 |
| E21-0461-05 | N | 4P push terminal | | 1 | L40-4701-03 | | Ferri-inductor 47μH | L43,50 | 2 |
| E23-0512-05 | | Terminal | | 2 | L40-4711-03 | | Ferri-inductor 470μH | L33 ~ 35,37 | 4 |
| E29-0434-05 | | 1P connector | | 1 | L40-4782-02 | | Ferri-inductor 0.47μH | L19,21 | 2 |
| E40-0273-05 | | Mini connector 2P | | 14 | L40-4791-02 | | Ferri-inductor 4.7μH | L2,5,25, | 3 |
| E40-0373-05 | | Mini connector 3P | | 1 | L40-4791-14 | | Ferri-inductor 4.7μH | L53 | 1 |
| E40-0473-05 | | Mini connector 4P | | 2 | L40-6825-04 | | Ferri-inductor 6.8mH | L49 | 1 |
| E40-0573-05 | | Mini connector 5P | | 3 | L40-6882-02 | | Ferri-inductor 0.68μH | L15,17,18, | 3 |
| J13-0039-05 | | Fuse holder | | 2 | L40-6891-02 | | Ferri-inductor 6.8μH | L27,28 | 2 |
| J31-0502-04 | | PC Board collar | | 12 | L40-8209-25 | | Ferri-inductor 82μH | L29,30 | 2 |
| J42-0428-05 | | PC Board bush | | 12 | L72-0316-05 | | Ceramic filter CFW 455E | F5 | 1 |
| L19-0324-05 | | Wide band width transformer | T1,2,4 | 3 | L72-0319-05 | | Ceramic filter CFW 455HT | F4 | 1 |
| L30-0503-05 | | IFT 455KHz | T21 | 1 | L72-0332-05 | | Ceramic filter CFW455K1 | F3 | 1 |
| L30-0504-05 | | IFT 455KHz | T20 | 1 | L72-0338-05 | N | Ceramic filter SFE9.8MK | F1 | 1 |
| L32-0646-05 | | OSC coil 455KHz, BFO | T19 | 1 | L79-0446-05 | | Ceramic discriminator CFY455S | F6 | 1 |
| L34-0540-05 | | Tuning coil 455KHz | T17 | 1 | N09-0641-05 | | Round screw | | 2 |
| | | | | | N10-2030-46 | | Screw | | 3 |
| | | | | | N30-3008-46 | | Screw | | 1 |
| | | | | | N30-3010-46 | | Screw | | 2 |
| | | | | | R12-1038-05 | | Trim. pot 1KΩ (B) | VR3, | 1 |
| | | | | | R12-1040-05 | | Trim. pot 4.7KΩ (B) | VR5, | 1 |
| | | | | | R12-1414-05 | | Trim. pot 1KΩ (B) | VR1, | 1 |
| | | | | | R12-2409-05 | | Trim. pot 5KΩ (B) | VR4, | 1 |
| | | | | | R12-3045-05 | | Trim. pot 10KΩ (B) | VR7,8, | 2 |
| | | | | | R12-3046-05 | | Trim. pot 47KΩ (B) | VR6 | 1 |
| | | | | | R12-5030-05 | | Trim. pot 100KΩ (B) | VR10 | 1 |
| | | | | | R12-6401-05 | | Trim. pot 470KΩ (B) | VR9 | 1 |
| | | | | | R90-0522-05 | | Resistor block 47KΩx6 | RA-1 | 1 |
| | | | | | R92-0150-05 | | Short jumper | | 70 |
| | | | | | S90-0406-05 | N | Slide switch, ATT | S1 | 1 |

R-2000

PC BOARD VIEW

16 RX UNIT (X55 - 1340 - 00) Component Side view

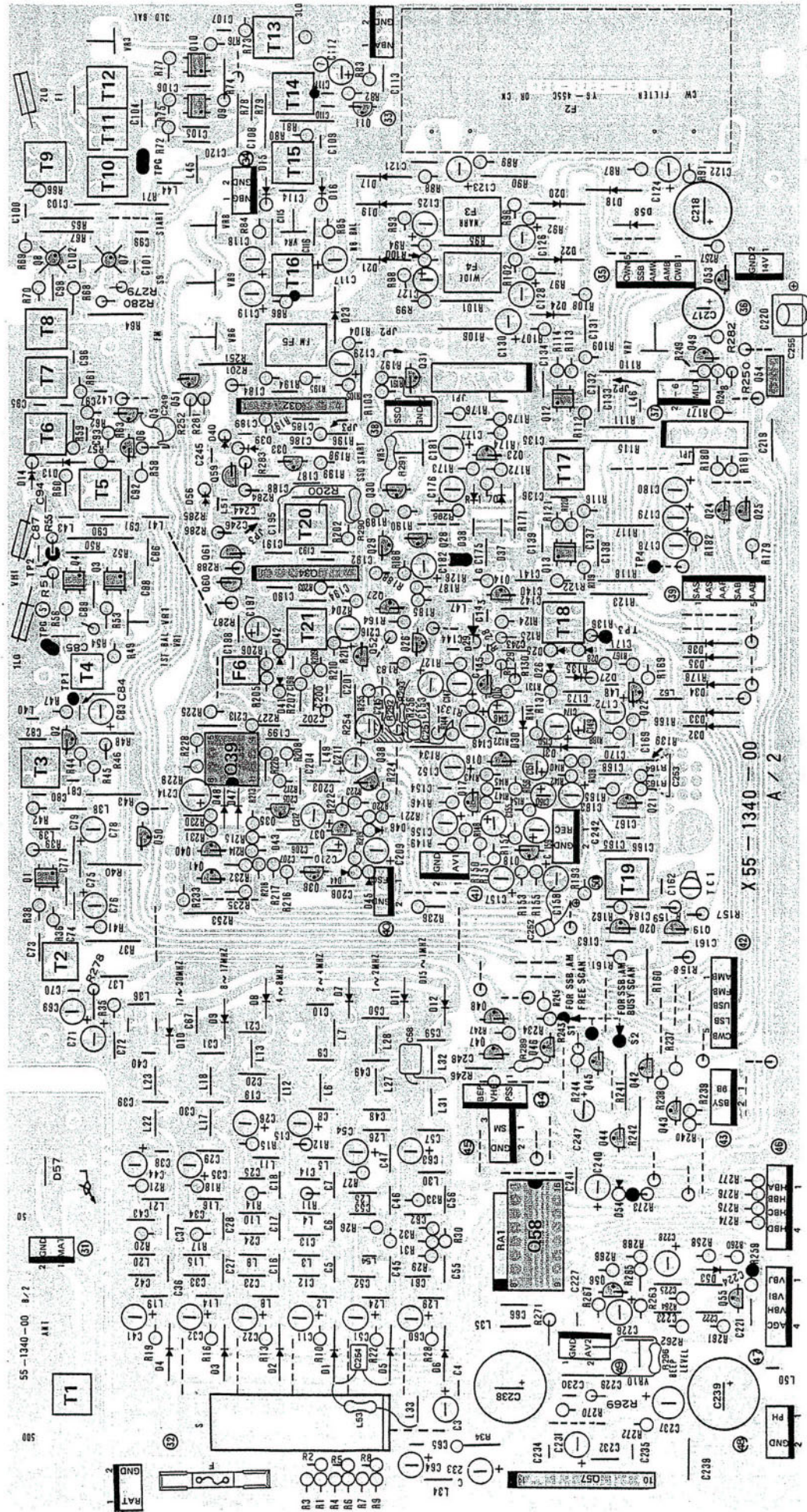

- 2SA1015 (Y)
- 2SC1675 (L)
- 2SC1775 (E)
- 2SC1815 (Y)
- 2SC1959 (Y)
- 2SC2240 (GR)
- 2SC2878

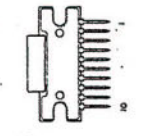
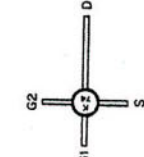

A B C D E F G

1

2

3

4

5

6

X55-1340-00
A / 2

R-2000

SCHEMATIC DIAGRAM PLL UNIT (X50-1920-00)

Measurement conditions.
 Freq.: 14.525 MHz, USB, RX no signal

: Signal line
 : Control line
 : Common DC line

: Test point
 : Adjusting point

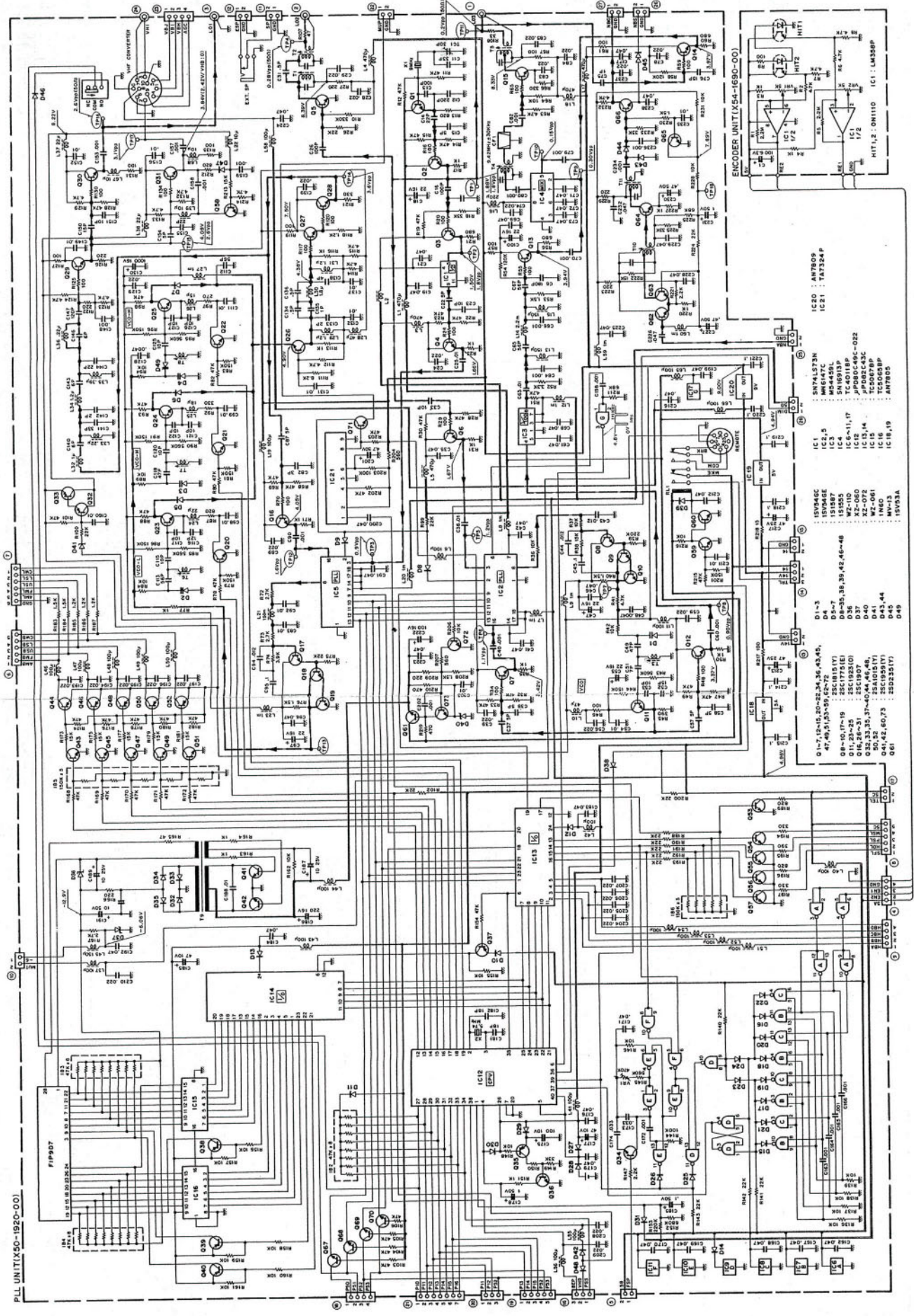

| | |
|------|--------------|
| IC1 | ANAL733N |
| IC2 | AN747C |
| IC3 | 5V5460C |
| IC4 | 151887 |
| IC5 | 5N193P |
| IC6 | TC4018P |
| IC7 | IC6-11,17 |
| IC8 | WZ-110 |
| IC9 | PP80C48C-022 |
| IC10 | AZ-080 |
| IC11 | WZ-100 |
| IC12 | WZ-081 |
| IC13 | TC5057P |
| IC14 | TC5058P |
| IC15 | TC5059P |
| IC16 | IN60 |
| IC17 | AN705 |
| IC18 | 15V33A |
| IC19 | 15V33A |

R-2000

PC BOARD VIEWS

PLL UNIT (X50-1920-00) Component side view

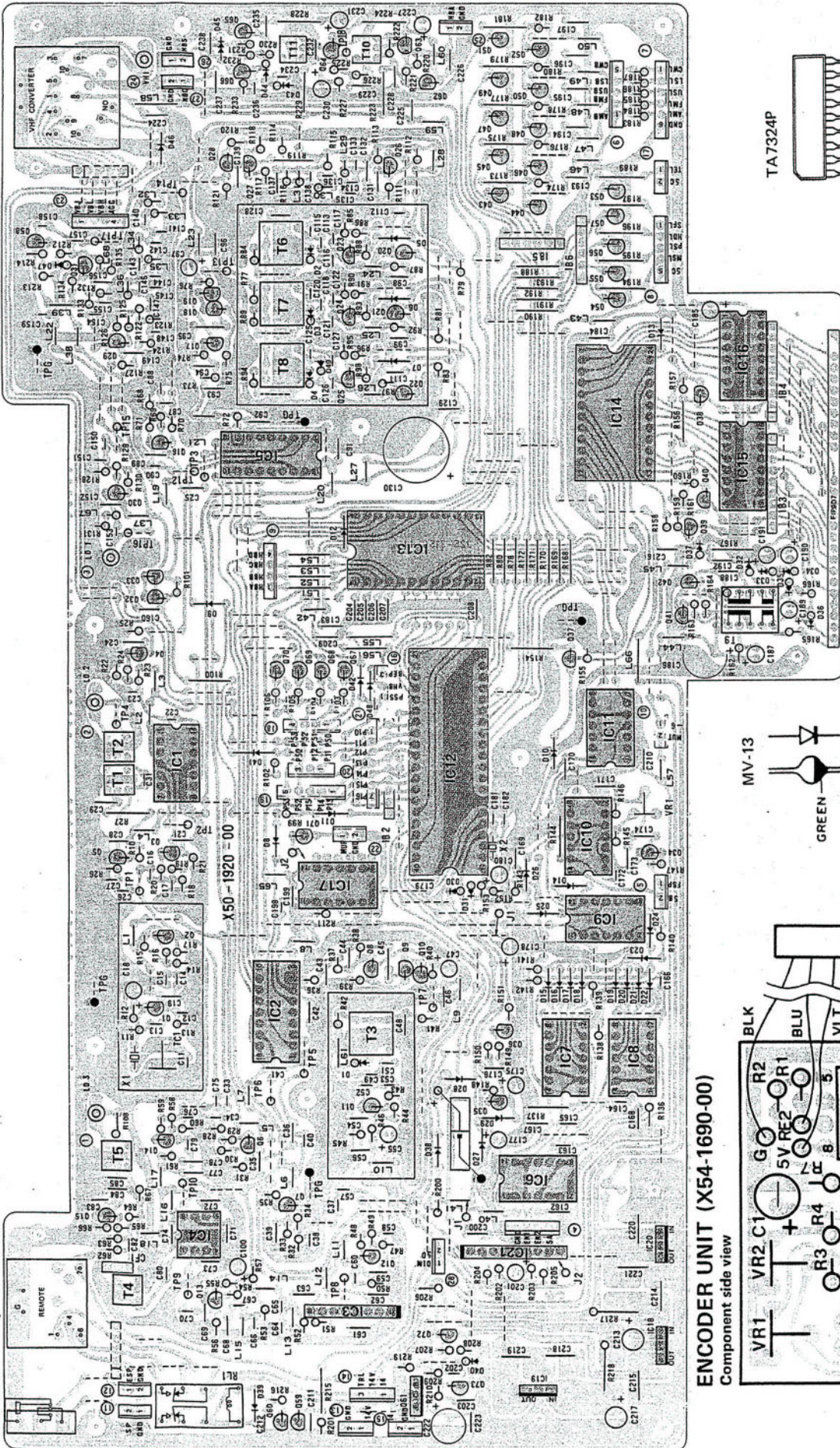

ENCODER UNIT (X54-1690-00)

Component side view

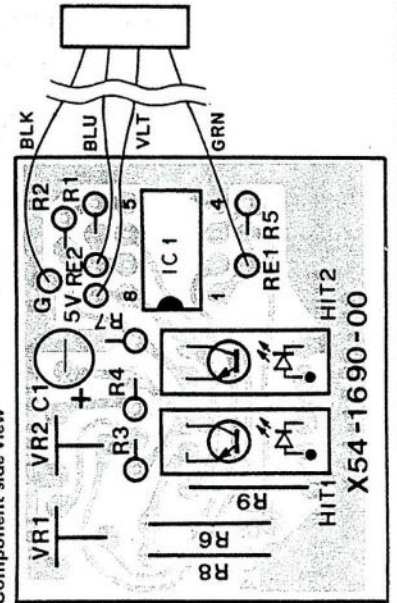

MV-13

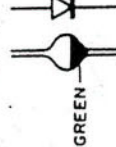

GREEN

AN7805
AN7809

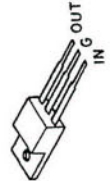

2SA1015 (Y)
2SC1775 (E)
2SC1815 (Y)
2SC1907



TA7324P

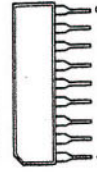

2SD235 (Y)



R-2000

PC BOARD VIEWS

20 SWITCH UNIT (X41 - 1480 - 00) Component side view

2SA1015(Y)

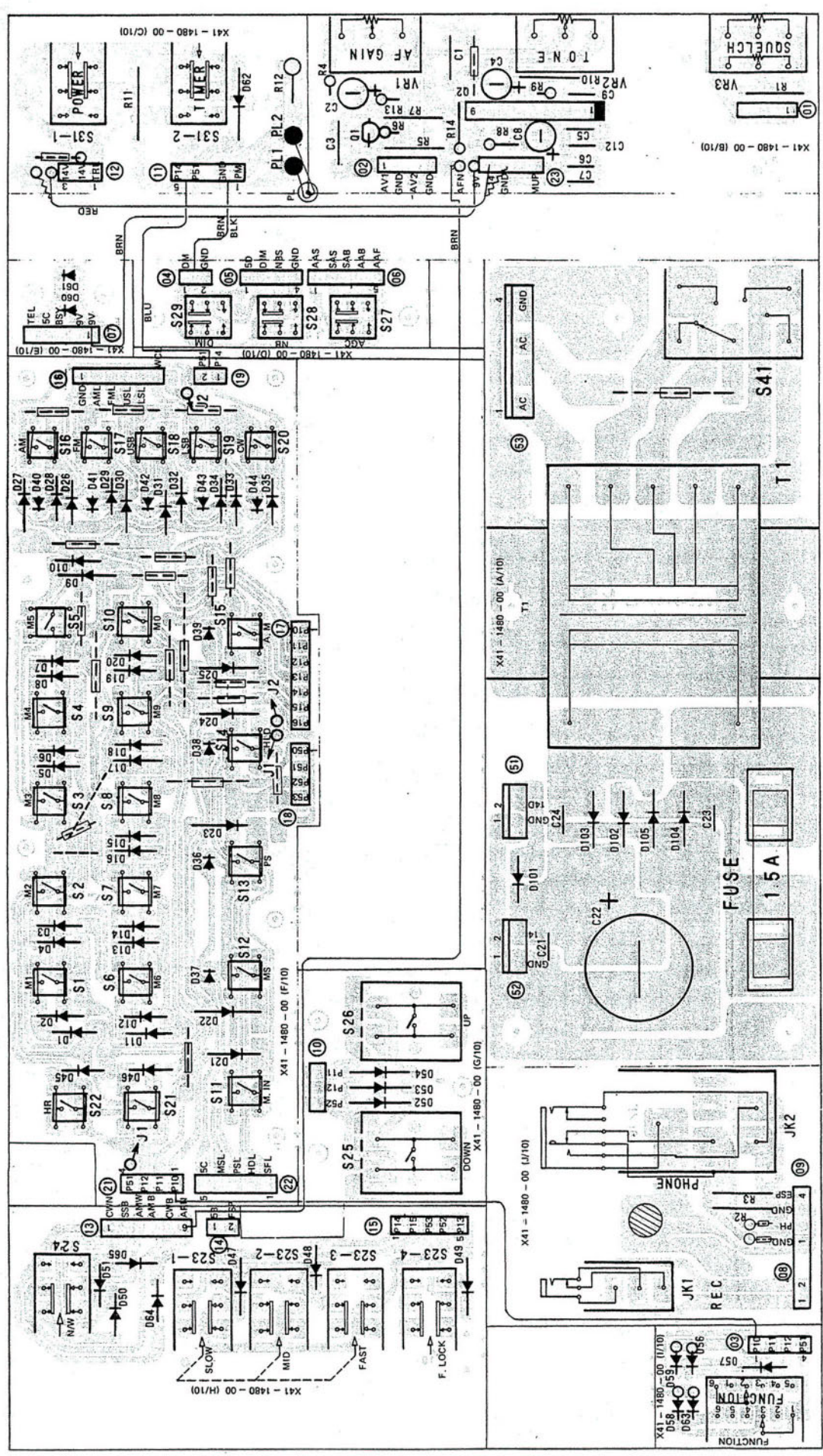

PACKING

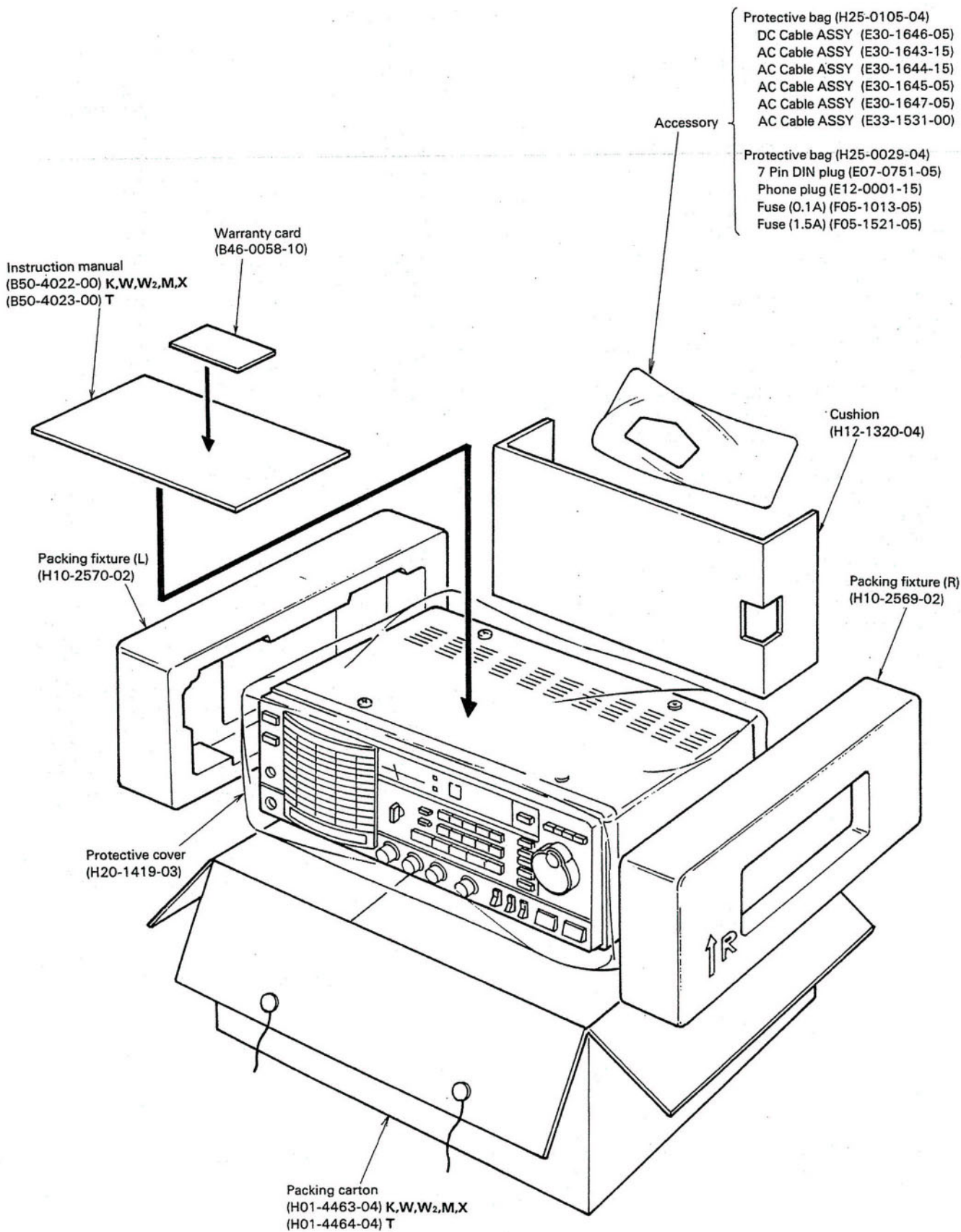

ADJUSTMENT

REQUIRED TEST EQUIPMENT

1. VTVM or DVM (DC VM)

- 1) Input resistance: More than 1 M Ω
- 2) Voltage range: 1.5 to 1000V DC

NOTE: A high-precision voltmeter may be used. However, accurate readings can not be obtained for high-impedance circuits.

2. AF VTVM (AF VM)

- 1) Frequency range: 50 Hz to 10 kHz
- 2) Input impedance: 1 M Ω or greater
- 3) Voltage range: 10 mV to 30V

3. AF DUMMY LOAD

- 1) Impedance: 8 Ω
- 2) Dissipation: 3W or greater

4. OSCILLOSCOPE

Requires high sensitivity and external synchronization capability.

5. STANDARD SIGNAL GENERATOR (SSG)

- 1) Frequency range: 100 kHz to 80 MHz
- 2) Output: -20 dB/0.1 μ V to 120 dB/1V
- 3) Output Z = 50 Ω
- 4) Should have AM modulation capability. Generator must be frequency stable.

6. FREQUENCY COUNTER

- 1) Minimum input voltage: 50 mV
- 2) Frequency range: Greater than 80 MHz

7. NOISE GENERATOR

Must generate ignition-like noise containing harmonics beyond 30 MHz.

PREPARATION

Unless otherwise specified, set the controls as follows.

| | |
|--------------------|-----------|
| POWER | ON |
| TIMER | OFF |
| FUNCTION | FREQUENCY |
| NARROW/WIDE | WIDE |
| TUNING SPEED | SLOW |
| F. LOCK | OFF |
| MODE | AM |
| AGC FAST | OFF |
| NB | OFF |
| DIMMER | OFF |
| AF GAIN | MIN |
| TONE | CENTER |
| SQUELCH | MIN |
| RF ATT | 0 |
| M.SCAN | OFF |
| PG.SCAN | OFF |
| AUTO.M | OFF |

REFERENCE

| Japanese "SSG" | American "SG" |
|----------------|---------------|
| -6 dB | 0.25 μ V |
| 0 dB | 0.5 μ V |
| 6 dB | 1 μ V |
| 12 dB | 2 μ V |
| 24 dB | 8 μ V |
| 30 dB | 15.8 μ V |
| 40 dB | 50 μ V |
| 50 dB | 158 μ V |
| 60 dB | 500 μ V |
| 70 dB | 1.58 mV |
| 80 dB | 5 mV |
| 90 dB | 15.8 mV |
| 100 dB | 50 mV |
| 120 dB | 0.5 V |

ADJUSTMENT

Adjusting PLL Section

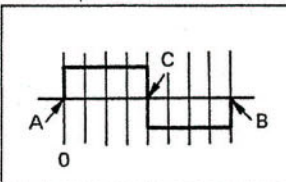
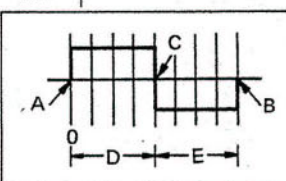
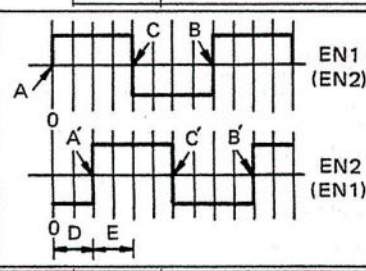
| Item | Condition | Measurement | | | Adjustment | | | Specifications | | | | | |
|-----------------------------------|--|-------------------|------|--------------------|------------|------|--|---|----------------------------|--|--|---|---|
| | | Test equipment | Unit | Terminal | Unit | Part | Method | | | | | | |
| 1. Reference oscillator frequency | 1) POWER: ON | Frequency counter | PLL | TP4 | PLL | TC1 | 36,000,000 Hz | ±20 Hz | | | | | |
| 2. VCO | 1) MODE: AM f: 17,000.0 kHz | DC VM | PLL | TP7 | PLL | T3 | 7.5V | ±0.05V | | | | | |
| | 2) f: 16,999.9 kHz | | | | | | Check | 2.3V or more | | | | | |
| 3. VCO-H | 1) MODE: AM f: 29,999.9 kHz (W2 type) f: 25,999.9 kHz | DC VM | PLL | TP13 | PLL | T8 | 7.8V | ±0.05V | | | | | |
| | 2) f: 17,000.0 kHz | | | | | | Check | 2.0V or more | | | | | |
| 4. VCO-M | 1) MODE: AM f: 16,999.9 kHz | DC VM | PLL | TP13 | PLL | T7 | 7.8V | ±0.05V | | | | | |
| | 2) f: 8,000.0 kHz | | | | | | Check | 2.0V or more | | | | | |
| 5. VCO-L | 1) MODE: AM f: 7,999.9 kHz | DC VM | PLL | TP13 | PLL | T6 | 7.8V | ±0.05V | | | | | |
| | 2) f: 100.0 kHz (W2 type) f: 150.0 kHz | | | | | | Check | 2.0V or more | | | | | |
| | (X type) f: 2,000.0 kHz | | | | | | Check | 3.0V or more | | | | | |
| 6. Encoder | 1) Remove the MAIN knob and motor-drive the encoder at approx. 300 rpm. | Oscilloscope | PLL | Connector ④-EN1 | | |  | Point C may be located anywhere. When motor drive is not available, manually turn the MAIN control to check the duty ratio. | | | | | |
| | 2) EN1 duty ratio adjustment: Turn a motor clockwise and counterclockwise. | | | | | | | | Encoder | VR1 |  | After adjusting with the MAIN control turned CW, check that intervals D and E are also identical when the MAIN control is turned CCW. | |
| | 3) EN2 duty ratio adjustment: Turn a motor in the both direction. | | | | | | | | Connector ④-EN2 | VR2 | | | Adjust until intervals D and E are equal to each other with point C placed at the center. |
| | 4) EN1, EN2 phase difference adjustment: Same as above. | | | | | | | | Connector ④-EN1 and EN2 |  | | | EN1 (EN2) EN2 (EN1) |
| 7. PG SCAN SPEED | 1) f: 15,000.0 kHz MEMORY CH: 9 Write in with M. IN switch. | | | | | | | | | | | | |
| | 2) f: 15,010.0 kHz MEMORY CH: 0 Write in with M. IN switch. | | | | | | | | | | | | |
| | 3) PG SCAN: ON | | | | PLL | VR1 | Turn clockwise/counterclockwise to check scan speed change. Set to mechanical center. | | | | | | |

ADJUSTMENT

Adjusting Receiver Section

| Item | Condition | Measurement | | | Adjustment | | | Specifications |
|----------------------------------|--|---|------------|-------------------|------------|----------------------|---|--|
| | | Test equipment | Unit | Terminal | Unit | Part | Method | |
| 1. RB voltage | | DC VM | RX | TP4 | RX | VR7 | 2.3V | |
| 2. BFO (Coarse adjustment) | 1) MODE: USB | Frequency counter | RX | TP3 | RX | T19 | 456,500 Hz | ± 50 Hz |
| 3. Sensitivity (RF,IF amp) | 1) f: 14,525.0 kHz MODE: USB AGC: FAST SSG output: 0 dBμ | SSG AF VM Oscilloscope AF dummy load | Rear panel | ANT | PLL | T1, T2, T4, T5 | MAX | |
| | | | | EXT SP | RX | T5 to T16, T18 | MAX Perform adjustment in the following order: T5, T6, T7, T8, T7, T6, T5, T9, T10, T11, T12, T11, T10, T11, T12, T11, T10, T13, T14, T15, T16, T18. | S/N: 10 dB or more |
| 4. 1st MIX BALANCE | 1) f: 187.3 kHz MODE: USB TUNING STEP: SLOW | AF VM Oscilloscope AF dummy load | Rear panel | EXT SP | RX | VR1 | MIN. Heterodyne | |
| 5. BFO (Fine adjustment) | 1) f: 14,525.0 kHz MODE: USB, then LSB | SP | | | RX | T19 | Alternate MODE between USB and LSB and adjust for equal noise tone. (Equal highs and lows) | |
| | 2) SSG output: 14.525 MHz 0 dBμ | SSG AF VM Oscilloscope AF dummy load | Rear panel | ANT EXT SP | | | Receive the 14.525 MHz generator signal in USB mode, tune for 1 kHz beat frequency, and AF output at 0.63V/8Ω. Set to LSB mode, adjust for 1 kHz beat and measure the AF output difference. | Within 1.5 dB |
| 6. FM sensitivity (FM IF amp) | 1) f: 14,525.0 kHz MODE: FM SSG output: 6 dBμ (MODE: 1 kHz DEV: 5 kHz) | SSG AF VM Oscilloscope AF dummy load | Rear panel | ANT | RX | T21 | MAX | S/N: 20 dB or more |
| | 2) SSG output: 6 to 100 dBμ | | | EXT SP | | | Confirm that the output is constant from 6 dB to 100 dB. | Specified output. |
| 7. S meter | 1) MODE: USB AGC: FAST | S meter | | | RX | VR8 | Zero adjustment. Set to S meter starting point. | |
| | 2) f: 14,525.0 kHz SSG output: 8 dBμ | SSG S meter | Rear panel | ANT | | T17 | S-1 Adjust CCW from the peak. | |
| | 3) SSG output: 30 dBμ | | | | | VR9 | S-9 | |
| | 4) MODE: FM SSG output: 30 dBμ | | | | | VR6 | +40 dB | |
| 8. Squelch | 1) MODE: FM AGC: SLOW SQUELCH: Threshold | SP | | | | | Check | Between 1 and 3 (Squelch level) BUSY indicator goes off. |
| | 2) MODE: USB | | | | RX | VR5 | Point at which noise disappears. | |
| | 3) f: 14,525.0 kHz MODE: USB SQUELCH: Threshold SSG output: 20 dBμ | SSG AF VM Oscilloscope AF dummy load | Rear panel | ANT | | | Check | The squelch should open at less than 20 dBμ and the BUSY indicator should light. |
| | 4) MODE: FM SQUELCH: Threshold SSG output: 0 dBμ | | | | | | | The squelch should open at less than 0 dBμ and the BUSY indicator should light. |

ADJUSTMENT

| Item | Condition | Measurement | | | Adjustment | | | Specifications |
|-----------------|---|---|------------|----------|------------|---|--------|--|
| | | Test equipment | Unit | Terminal | Unit | Part | Method | |
| 9. NB | 1) f: 14,525.0 kHz MODE: AM WIDE/NARROW: WIDE NB: ON Noise generator output level: S meter indicator 5 ± 1 | Noise generator | Rear panel | ANT | RX | VR4 | MIN | S1 or less (Typical) |
| | PLL | | | | T10, T11 | Repeat steps 1) and 2) so the NB functions on noise which is below the minimum S meter level. | | |
| 10. 1st IF trap | 1) f: 29,525.0 kHz MODE: USB SSG output: 45.875 MHz 90 dB μ | SSG AF VM Oscilloscope AF dummy load | Rear panel | ANT | RX | T3 | MIN | 70 dB or more |
| 11. "Beeper" | 1) AFGAIN: Center TONE: Center SQUELCH: Closed (No noise) * Connect R259 and R273. (Disconnect after adjustment.) | AF VM Oscilloscope AF dummy load | Rear panel | EXT SP | RX | VR10 | 0.3V | Tone should remain audible even when the AFGAIN is reduced to MIN. |

< Microprocessor operational check >

| Item | Condition | Operation Check |
|--|---|---|
| 1. Encoder (Dial) | 1) TUNING SPEED: SLOW Turn the tuning control clockwise and counterclockwise. | Display changes in 100 Hz steps. |
| | Turn the main tuning 1 turn. | Display changes 10 kHz. |
| | 2) TUNING SPEED: MID Turn the tuning control clockwise and counterclockwise. | Display changes in 500 Hz step. |
| | Turn the main tuning 1 turn. | Changes 100 kHz. |
| 3) TUNING SPEED: FAST Turn the tuning control clockwise and counterclockwise. | Changes in 5 kHz step. | |
| | Turn the main tuning 1 turn. | Changes 1 MHz. |
| 2. BAND | 1) TUNING SPEED: FAST Keep the UP switch depressed until tuning stops. Then turn the tuning control clockwise. | The MHz digit scans up in 1 MHz steps and stop when the display indicates 29,995.0 kHz. W2 type stops tuning at 25,995.0. |
| | Keep the DOWN switch depressed until tuning stops. Turn the tuning control counterclockwise. | The MHz digit scans down to 0.100.0 at a 1 MHz step. W2 type stops tuning at 0.150.0 and X type stops at 2.000.0 |
| 3. F. LOCK | 1) F. LOCK: ON Turn the tuning control and BAND knob. | The display should not change. |

| Item | Condition | Operation Check |
|--|--|---|
| 4. DIMMER | DIMMER: ON | The S meter and display illumination should be reduced. |
| 5. CLOCK and TIMER | 1) POWER: OFF FUNCTION: CLOCK 1 | The clock should function. The illumination should be dim. |
| | 2) TIMER: ON | * TIMER ERROR (red) indicator should light. * CLOCK display flashes. |
| | 3) TIMER: ON Simultaneously press both the HOUR and MINUTE TIME SET switches. | * CLOCK display should be 0:00. * TIMER ERROR (red) indicator should go off. |
| | 4) FUNCTION: CLOCK 2 Keep the HOUR and MINUTE switches depressed. | The display should continuously advance. |
| | Set the hours digit. | The display should indicate the time difference from CLOCK 1. |
| | 5) FUNCTION: ON Set the TIMER display to 0.02. | |
| | 6) FUNCTION: OFF Set the TIMER display to 0.03. | |
| 7) FUNCTION: CLOCK 1 Set the TIMER display to 0.02. | Power should turn on and the unit should function. | |
| Set the TIMER display to 0.03. | Power should shut off. | |

ADJUSTMENT

| Item | Condition | Operation Check |
|--------------------|--|---|
| 6. RECALL and MODE | 1) POWER: ON TIMER: OFF FUNCTION: FREQUENCY Press memory switches (1 through 0). | <ul style="list-style-type: none"> The MEMO indicator should change from 1 through 0. The frequency display should indicate 15,000.0 for each channel. |
| | Press MODE AM, FM, USB, LSB and CW switches. | <ul style="list-style-type: none"> The green indicators should light for AM and FM modes. The yellow indicators should light for USB, LSB and CW modes. |
| 7. MEMORY | 1) MODE: USB Press the M. IN switch and store 10,615.0 in channel 9. | The beep should be heard when data is stored in channels 9 and 0. |
| | Press the M. IN switch and store 10,635.0 in channel 0. | |
| 8. M. SCAN | 1) M. SCAN: ON | The M. SCAN indicator (green) should light and each channel should be scanned for 2 seconds. |
| | 2) HOLD: ON (Release after test) | The scan should stop and the HOLD indicator (red) should light. When the HOLD switch is again depressed, scanning should resume. |
| 9. Select SCAN | 1) M. SCAN: ON Press channels 1 through 3 and then channel 2 again (twice). | "C" should be displayed on the MEMO indicator and channels 1 and 3 should be scanned continuously. |
| 10. PG. SCAN | 1) PG. SCAN: ON | <ul style="list-style-type: none"> The PG. SCAN indicator (yellow) should light. "P" should be displayed on the MEMO indicator and the USB indicator should light. The scan should start from 10,615.0 at 5 kHz interval. When 10,635.0 is reached, a "beep" should sound and the scan should restart from 10,615.0. |
| | 2) HOLD: ON Turn the tuning control clockwise and counter-clockwise. | Scan should stop. The frequency should change from 10,615.0 to 10,635.0. |

| Item | Condition | Operation Check |
|--------------|--|--|
| 11. AUTO. M | 1) AUTO. M: ON Press channel 1 and store 17,000.0 then press channel 2 and 1. | The AUTO. M indicator (green) should light and 17,000.0 should be displayed. |
| 12. Reset | 1) POWER: OFF Keep the power cable connected to the receiver and disconnect the lithium battery (-) terminal. | |
| | Disconnect the power cable and ground IC12 pin 40. (IC12: μ PD80C49C-022) | |
| | Reconnect the power cable. POWER: ON AUTO. M: ON | Indication MEMO: E f : 150,055.0 |
| | Disconnect, then reconnect the power cable. | Indication MEMO: 1 f : 15,000.0 |
| | POWER: OFF Reconnect the lithium battery (-) terminal. | |
| 2) POWER: ON | | Indication MEMO: 1 f : 15,000.0 |
| | Disconnect the power cable. Reconnect the power after approximately 30 minutes. | The memory contents should be retained and the above should be displayed |
| | | |
| 3) MEMORY: 1 | | Indication MEMO: 1 f : 15,000.0 |
| | MEMORY: 2 | MEMO: 2 f : 15,000.0 |
| | ⋮ MEMORY: 0 | ⋮ MEMO: 0 f : 15,000.0 |

ADJUSTMENT POINT

▼ TOP VIEW

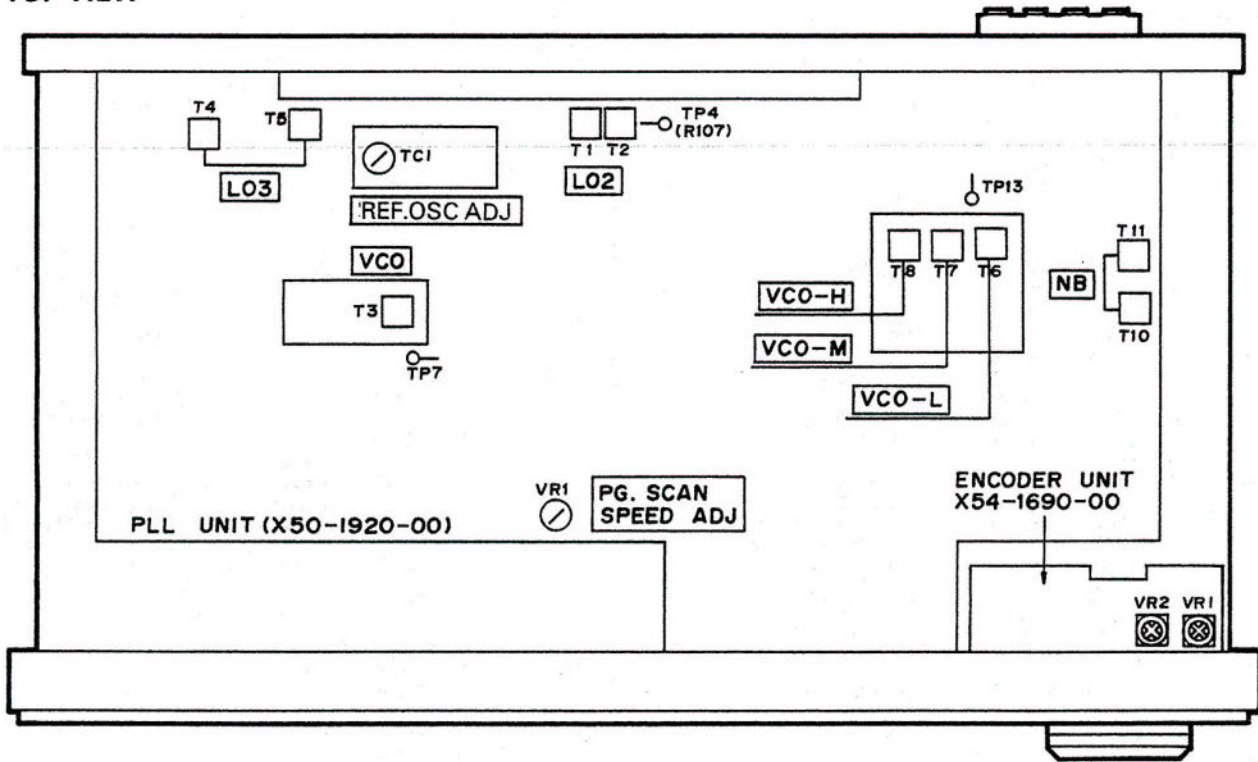

▼ BOTTOM VIEW

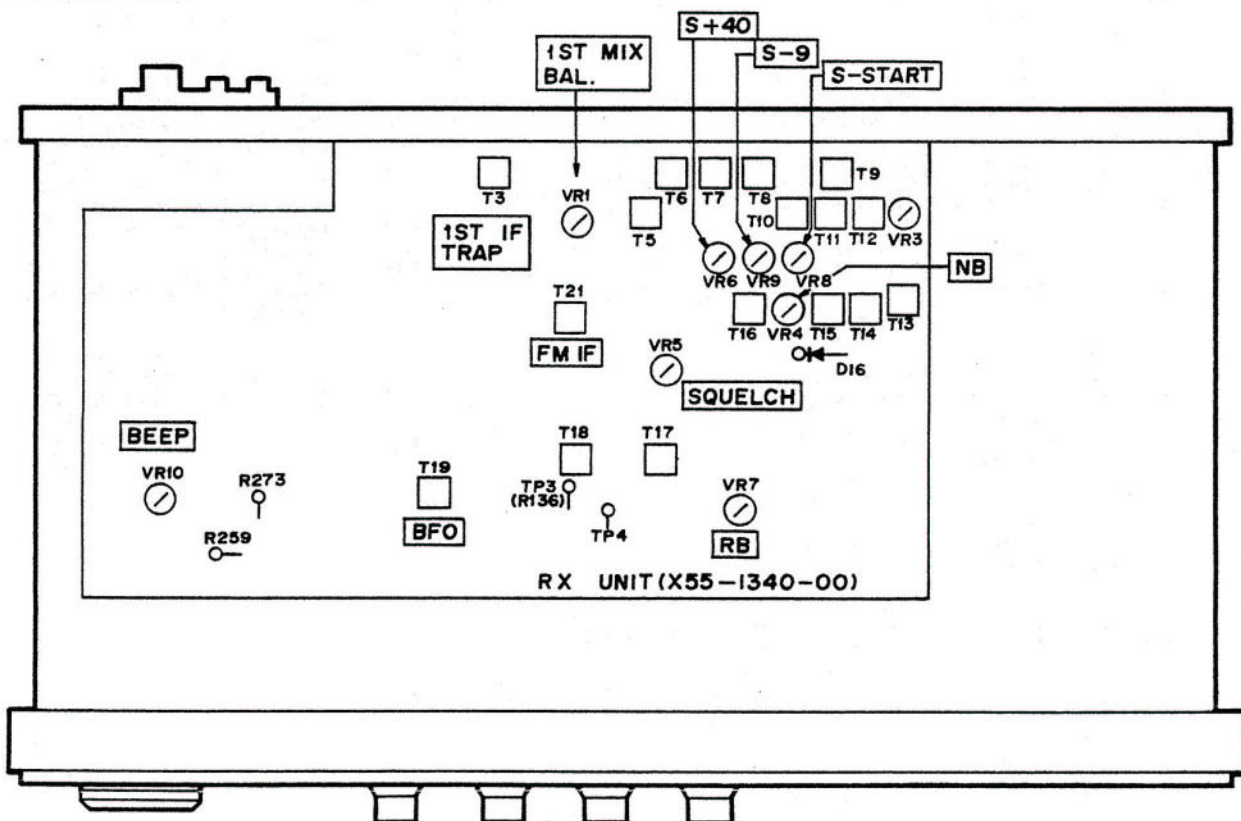

TERMINAL FUNCTION

PLL unit

| Connector No. | Terminal No. | Name | Destination | Function |
|---------------|--------------|------|-------------|------------------------------------|
| 1 | | L03 | RX | 3rd Local OSC output |
| 2 | | L02 | RX | 2nd Local OSC output |
| 3 | | L01 | RX | 1st Local OSC output |
| 4 | 1 | 5A | Encoder | 5V line |
| | 2 | EN2 | Encoder | Pulse input |
| | 3 | EN1 | Encoder | Pulse input |
| | 4 | GND | Encoder | |
| 5 | 1 | FSP | Switch | Program SCAN speed adjust terminal |
| | 2 | 5B | Switch | 5V line |
| 6 | 1 | AMB | RX | AM, 9V line |
| | 2 | FMB | RX | FM, 9V line |
| | 3 | USB | RX | USB, 9V line |
| | 4 | LSB | RX | LSB, 9V line |
| | 5 | CWB | RX | CW, 9V line |
| 7 | 1 | CWL | Switch | CW LED (Y) light |
| | 2 | LSL | Switch | LSB LED (Y) light |
| | 3 | USL | Switch | USB LED (Y) light |
| | 4 | FML | Switch | FM LED (G) light |
| | 5 | AML | Switch | AM LED (G) light |
| | 6 | GND | Switch | |
| 8 | 1 | SFL | Switch | AUTO-M LED (G) light |
| | 2 | HDL | Switch | HOLD LED (R) light |
| | 3 | PSL | Switch | P.SCAN LED (Y) light |
| | 4 | MSL | Switch | M.SCAN LED (G) light |
| | 5 | 5C | Switch | 5V line |
| 9 | 1 | HBA | RX | BPF select signal |
| | 2 | HBB | RX | BPF select signal |
| | 3 | HBC | RX | BPF select signal |
| | 4 | HBD | RX | BPF select signal |
| 10 | 1 | -6 | RX | -6V line |
| | 2 | MUT | RX | MUTE control |
| 11 | 1 | GND | SP | |
| | 2 | SP | SP | Speaker line |
| 12 | 1 | ESP | Phone jack | |
| | 2 | GND | Phone jack | |
| 13 | 1 | 14V | RX | RX 14V line |
| | 2 | GND | RX | |
| 14 | 1 | 14 | Switch | 14V line |
| | 2 | 14V | Switch | 14V line |
| | 3 | 14L | Switch | 14V line |
| 15 | 1 | GND | Switch | |
| | 2 | 14 | Switch | 14V line |
| 16 | 1 | PSS | RX | Program SCAN stop input |
| | 2 | VHB | RX | VHF signal output (VHF:H) |
| | 3 | BEP | RX | BEEP control output (BEEP:H) |
| 17 | 1 | TEL | Switch | Timer error, LED(R)light |
| | 2 | 5C | Switch | 5V line |
| 18 | 1 | P50 | Switch | Output common bus |
| | 2 | P51 | Switch | Output common bus |
| | 3 | P52 | Switch | Output common bus |
| | 4 | P53 | Switch | Output common bus |
| 19 | 1 | P13 | Switch | Input data bus |
| | 2 | P14 | Switch | Input data bus |
| | 3 | P15 | Switch | Input data bus |
| | 4 | P52 | Switch | Output common bus |
| | 5 | P53 | Switch | Output common bus |
| 20 | 1 | P11 | Switch | Input data bus |
| | 2 | P12 | Switch | Input data bus |
| | 3 | P52 | Switch | Output common bus |
| 21 | 1 | P10 | Switch | Input data bus |
| | 2 | P11 | Switch | Input data bus |
| | 3 | P12 | Switch | Input data bus |
| | 4 | P13 | Switch | Input data bus |
| | 5 | P14 | Switch | Input data bus |
| | 6 | P15 | Switch | Input data bus |
| | 7 | P16 | Switch | Input data bus |
| 22 | 1 | MUP | Switch | Unlock AF muting output |
| | 2 | GND | Switch | |
| 23 | 1 | VBJ | RX | VHF converter, Band input |
| | 2 | VBI | RX | VHF converter, Band input |
| | 3 | VBH | RX | VHF converter, Band input |
| | 4 | AGC | RX | VHF converter, AGC input |
| 24 | | VHI | RX | VHF converter, IF output |
| 25 | 1 | NBA | RX | NB, IF input |
| | 2 | GND | RX | |
| 26 | 1 | GND | Switch | |
| | 2 | NBS | Switch | NB switch, GND:ON |
| 27 | 1 | NBG | RX | NB switching pulse output |
| | 2 | GED | RX | |
| 28 | 1 | DIM | Switch | Dimmer switch |
| | 2 | 5D | Switch | 5V line |

RX unit

| Connector No. | Terminal No. | Name | Destination | Function |
|---------------|--------------|------|----------------|--|
| 31 | 1 | MAT | UHF Receptacle | |
| | 2 | GND | | |
| 32 | 1 | RAT | | Receiver input |
| | 2 | GND | | |
| 33 | 1 | NBA | PLL | NB, IF output |
| | 2 | GND | PLL | |
| 34 | 1 | NBG | PLL | NB, Switching pulse input |
| | 2 | GND | PLL | |
| 35 | 1 | CWB | Switch | CW, 9V line input |
| | 2 | AMB | Switch | AM, 9V line input |
| | 3 | AMW | Switch | AM wide, 9V line input |
| | 4 | SSB | Switch | SSB, 9V line input |
| | 5 | CWN | Switch | CW narrow, 9V line input |
| 36 | 1 | 14V | PLL | 14V input |
| | 2 | GND | PLL | |
| 37 | 1 | -6 | PLL | -6V input |
| | 2 | MUT | PLL | Muting control signal input |
| 38 | 1 | SSQ | Switch | SSB, squelch Adj input |
| | 2 | GND | Switch | |
| 39 | 1 | SAS | Switch | AGC select (SSB SLOW) |
| | 2 | AAS | Switch | AGC select (AM SLOW) |
| | 3 | AAF | Switch | AGC select (AM FAST) |
| | 4 | SAB | Switch | AGC select (SSB AGC reference voltage) |
| | 5 | AAB | Switch | AGC select (AM AGC reference voltage) |
| 40 | 1 | FSQ | Switch | FM squelch Adj input |
| | 2 | GND | Switch | |
| 41 | 1 | AV1 | Switch | AF pre-amp, output |
| | 2 | GND | Switch | |
| 42 | 1 | AMB | PLL | AM, 9V input |
| | 2 | FMB | PLL | FM, 9V input |
| | 3 | USB | PLL | USB, 9V input |
| | 4 | LSB | PLL | LSB, 9V input |
| | 5 | CWB | PLL | CW, 9V input |
| 43 | 1 | 9V | Switch | 9V line output |
| | 2 | BSY | Switch | BUSY LED (G) |
| 44 | 1 | PSS | PLL | Program scan stop signal output |
| | 2 | VHB | PLL | High when VHF, RX |
| | 3 | BEP | PLL | Beeper control input |
| 45 | 1 | SM | Smeter | S-meter (+) |
| | 2 | GND | Smeter | |
| 46 | 1 | HBA | PLL | Band data input |
| | 2 | HBB | PLL | Band data input |
| | 3 | HBC | PLL | Band data input |
| | 4 | HBD | PLL | Band data input |
| 47 | 1 | VBJ | PLL | VHF converter, Band data output |
| | 2 | VBI | PLL | VHF converter, Band data output |
| | 3 | VBH | PLL | VHF converter, Band data output |
| | 4 | AGC | PLL | VHF converter, AGC output |
| 48 | 1 | PH | Phone jack | AF output |
| | 2 | GND | Phone jack | |
| 49 | 1 | GND | Switch | |
| | 2 | AV2 | Switch | AF power AMP input |
| 50 | 1 | REC | REC jack | |
| | 2 | GND | | |
| | | L01 | PLL | 1st Local OSC input |
| | | L02 | PLL | 2nd Local OSC input |
| | | L03 | PLL | 3rd Local OSC input |
| | | VHI | PLL | VHF converter, IF |

DCK-1 D.C. OPERATION KIT (OPTION)

PARTS LIST

| Ref. No. | Part No. | Description | Re- marks |
|----------|-------------|-------------------------------|--------------|
| - | B50-2703-00 | Instruction sheet | |
| - | E08-0203-25 | Cable with 2P connector | |
| - | E31-2027-05 | Cable with terminal | |
| - | E30-1646-05 | DC cable ass'y | |
| - | F05-1023-05 | Fuse UL 1A x 2 | |
| - | H25-0029-04 | Protective bag 60 mm x 110 mm | |
| - | H25-0117-04 | Protective bag 80 mm x 250 mm | |

A product of

TRIO-KENWOOD CORPORATION

17-5, 2-chome, shibuya, shibuya-ku Tokyo 150, Japan

TRIO-KENWOOD COMMUNICATIONS

1111 West Walnut Street, Compton, California, 90220, U.S.A.

TRIO-KENWOOD COMMUNICATIONS, GmbH

D-6374 Steinbach TS, Industriestrasse 8A, West Germany

TRIO-KENWOOD ELECTRONICS, N.V.

Leuvensesteenweg 504, B-1930 Zaventem, Belgium

TRIO-KENWOOD (AUSTRALIA) PTY. LTD.

4E Woodcock Place, Lane Cove N.S.W. 2066, Australia